

*Shunsuke HANEHARA  
Faculty of Engineering, Iwate University  
4-3-5, Ueda, Morioka-city, Iwate-prefecture, Japan 020-8551*

*Kazuo YAMADA  
R&D Center, Taiheiyo Cement Corp.  
2-4-2, Osaku, Sakura-city, Chiba-prefecture, Japan 285-8655*

Rheology and Early Age Properties of Cement Systems – Part 1

## **1. Rheology of cement-based materials**

### **1.1 Rheological characteristics of cement based materials**

Strength, hardening properties (stability in dimensions), and durability are required as the ultimate performance for cement-based materials and concrete. However, whether these are realized or not depends on the rheological properties of the fresh materials. The initially designed performance is achieved only when the fresh concrete is mixed and transported without causing segregation, the subsequent proper placement process into the form is executed, and proper curing is performed. The rheology of concrete is often characterized by its workability. The workability of concrete is a performance index representing how easily it is constructed when used in actual structures, and is a collective term of general performance that includes easiness of being mixed, transportability, void-filling ability, compactibility, finishability, and resistance against segregation [1]. There are many test methods to evaluate the workability as shown in Table 1 [1].

Among these, the slump test has played an important role for more than fifty years. It is simple and able to produce highly reproducible data. However, at the same time, there are many drawbacks such that it cannot be easily interpreted in terms of the concrete's rheology. If any physical quantity representing the flowability could be proposed in a more quantitative manner, it would contribute to ensure the stability of the concrete quality, to rationalize its production, and to rationalize and economize the construction process. Many properties concerning the deformation and flowability of cement-based materials and concrete in their fresh state have been investigated in the discipline of rheology. In cement-based materials in which cement particles are suspended in water, many factors such as the settling separation by difference in density between cement particles and water, coagulation caused by generation of hydration products from the cement particles, and differences in surface charges attributed to particles consisting of different minerals which frequently cause particle coagulation, change significantly as a function of time and significantly complicate a complete rheological characterization.

Recent technological developments of chemical admixtures have made it possible to control the flowability of cement-based materials and concrete for the required purposes. However, it has been reported that changes in flowability caused by a particular combination of admixture and cement are affected by the hydration of cement itself and/or the characteristics of the subsequent adsorption of the admixtures. This paper discusses types and performance of admixtures, as well as their mechanisms of plasticization, characteristics of flowability, and compatibility between admixtures and cements, and also refers to the flow characteristics of self-compacting concrete introduced into the marketplace within the last 10 to 20 years.

Table 1 Test methods for workability [1]

Consistency, Flowability		
Test methods for flowability		
Under mixing		
Consistency test in mixing		
		<ul style="list-style-type: none"> <li>Loading electricity</li> <li>Consuming electricity</li> <li>Electricity Index</li> <li>Torque</li> </ul>
After mixing		
	Gravity	<ul style="list-style-type: none"> <li>Slump test</li> <li>Slump flow test</li> <li>Drop test</li> </ul>
	Impact	<ul style="list-style-type: none"> <li>Flow table test</li> <li>DIN extended flow test</li> <li>Remolding test</li> <li>Vibrating compaction test</li> <li>Drop table test</li> </ul>
	Vibration	<ul style="list-style-type: none"> <li>Vee Bee consistency test</li> <li>Vibration workability test</li> <li>Vibration flow test</li> </ul>
	Penetration test	<ul style="list-style-type: none"> <li>Iribarren test</li> <li>Kelly ball test</li> <li>German penetration test</li> <li>Workability test with impact-penetrometer</li> </ul>
Compactibility		
Test for compactibility		
	Gravity	<ul style="list-style-type: none"> <li>Compacting factor test</li> <li>Box-type flow test</li> <li>L-type flow test</li> <li>Test for passability through obstacles</li> </ul>
	Vibration	<ul style="list-style-type: none"> <li>Test for compactibility with vibrator</li> <li>Test for compaction and flow</li> </ul>
	Segregation test	
	Gravity	<ul style="list-style-type: none"> <li>Drop and segregation test</li> <li>Test for flowability</li> </ul>
	Impact	<ul style="list-style-type: none"> <li>Sieving test</li> </ul>
Pumpability		
	Pumpability test	<ul style="list-style-type: none"> <li>Test for bleeding in pumping</li> <li>Test for sliding-friction in horizontal tube</li> <li>Test for pumping in horizontal tube</li> </ul>

**1.2 Rheology of cement paste**  
**1) Evaluation of Rheology**

The determination of viscosity is important for knowing the state (or physical property) or fluidity of liquids and gases. A fluid in which tangential stresses are not generated during its movement (flowing state), like gases, is called a perfect fluid or an inviscid fluid.

Almost all fluids are viscous fluids. For example, when water in a cylindrical container is rotated around the vertical center axis of the container, the water initially at a still condition, will start to move by being dragged by the wall of the container, and finally will rotate as a whole like a rigid body. This is because a (tangential) force is generated at the boundary between the water and the wall of the container in the direction of the flow. Fluids in which such forces emerge are known as fluids having viscosity. Viscous fluids are further classified into two categories; one is a Newtonian fluid in which Newton's law of viscosity is applicable, and the other is a non-Newtonian fluid in which Newton's law of viscosity is not applicable.

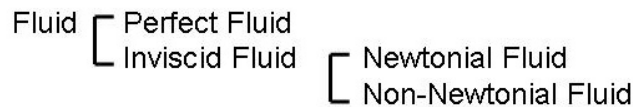

The coefficient of viscosity is the physical constant representing the magnitude of the ease with which the fluid will flow. As shown in Fig. 1, two parallel plates A and B are separated by a distance  $y_0$ , and liquid (fluid) is filled in the space in between. When the plate A is fixed and the plate B is moved parallel to the plate A at a constant velocity,  $V_0$ , the fluid between A and B also moves and a steady flow field is generated. If the velocity at a certain distance  $y$  between A and B is taken as  $V$ , those two variables are proportional as shown in Fig.1, and the inclination,  $D$ , that is the grade of the straight line  $OP$ , shall be described as,

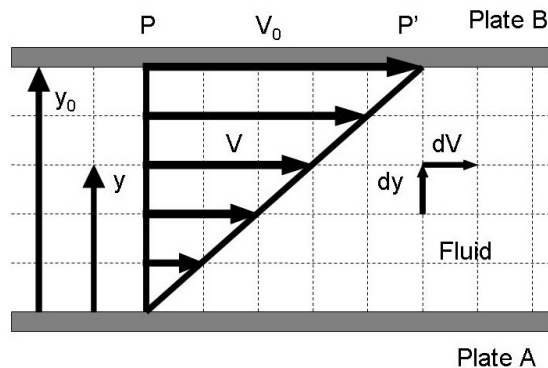

Fig.1 Newtonian flow.

$$D = V/y$$

$$\text{Eq(1)}$$

As this is equal to an increment of the velocity per unit distance, that is the velocity gradient,

$$D = dV/dy \quad \text{Eq.(1')}$$

D determined in this manner is called the shear rate.

In Fig.1 the layers at distance y, and y + dy, flow in parallel at velocity V, and V + dV, respectively, and the inner friction force is generated between the two layers due to the difference in those velocities. The friction force which acts between the plates A and B on the surface parallel to the flow direction per unit area is called the tangential stress. The tangential stress is also called the shearing stress. If the shear stress is expressed as  $\tau$ , it can be described as follows, where  $\mu$  is set as a proportional parameter to the shear rate,

$$\tau = \mu D \quad (\text{Newton's law of viscosity}) \quad \text{Eq.(2)}$$

The law expressed in the above formula is known as Newton's law of viscosity and the proportional constant,  $\mu$ , is the viscosity.

$$\mu = \tau / D \quad \text{Eq.(3)}$$

A fluid which follows Newton's law of viscosity, that is for which  $\mu$  is constant at a certain temperature, and does not depend on the shear rate, D, nor the shear stress,  $\tau$ , is called a Newtonian fluid. A fluid in which this proportional relationship does not hold (e.g., viscosity is not a constant) is called a non-Newtonian fluid. Many fluids consisting of a single substance, such as water or alcohol, are Newtonian fluids. On the other hand, liquids such as polymer solutions, or colloidal solutions, are generally considered to be non-Newtonian fluids.

When the relationship between the shear rate, D and the shear stress  $\tau$ , is expressed as shown in Fig.2, a Newtonian fluid is described by curve  $\tau = \mu D$ . If we let the gradient be  $\mu$ , the viscosity,  $\mu$ , can be redefined in the following Eq.(4),

$$\mu = \tau / D \quad \text{Eq.(4)}$$

Fluids described by the lines from  $\tau = \mu_0 D$  to  $\tau = \mu_0 D + \tau_0$  are non-Newtonian fluids and the viscosity  $\tau/D$  is not constant, but varies depending on the shearing velocity. Typical examples of these types of fluids are shown in Table 2.

$\tau = \mu_0 D$  is called a dilatant fluid, and its viscosity increases as the shear rate increases.  $\tau = \mu_0 D + \tau_0$  is called a pseudoplastic fluid, and its viscosity decreases as the shear rate increases.  $\tau = \tau_0 + \mu_0 D$  is called a plastic fluid, and even as the shear rate is increased from zero, this type of fluid does not flow unless its shearing stress exceed the limit shearing stress,  $\tau_0$  (yield stress). The fluid

in which the linear relationship between  $\dot{\gamma}$  and  $\tau$  is confirmed after the yield stress, is called a Bingham fluid, and the fluid in which a nonlinear relationship is confirmed, is called a non-Bingham fluid. Cement-based materials correspond to non-Bingham fluids, but rheological analysis is often applied by assuming it to be a Bingham fluid. The slump is related to the yield stress value.

$\dot{\gamma}$  is called a thixotropic fluid, in which hysteresis is generated between the increasing and the decreasing of the shear rate. This is generally caused by a gel-sol transition during fluidization.

Table 2 Examples of types of fluids

Type of fluid	Typical examples
1 Newtonian fluid	water, alcohol
2 dilatant fluid	water solution of starch
3 pseudoplastic fluid	mayonnaise, colloids
4 Bingham fluid	tomato ketchup
4' non-Bingham fluid	asphalt(cement-based materials)
5 thixotropic fluid	grease (cement-based materials)



Fig.2 Shear stress vs. shear rate for Newtonian and non-Newtonian fluids.

## 2) Determination of rheology of cement paste

In order to acquire the behavior of shear stress as a function of the shear rate in a time series, using a rotating viscometer is indispensable. However, due to the differences among instruments in terms of their measurement range or the shape of the rotor, and the differences among researchers in the maximum shear rate and the rate of those changes, a valid data comparison is often difficult. In addition, the flow curve is frequently drawn as a loop of up-curves and down-curves, or sometimes as a complicated hysteresis loop. Therefore the flowability for cement-based materials and concrete is often evaluated by using the flow, the ratio of flow area, or the time to pass through a funnel as substitute parameters for the yield stress or the plastic viscosity.

Y. Yamada [2] states that there have been two viewpoints on rheology, phenomenological rheology in which analysis is done from the fluid mechanics viewpoint, and materials science rheology. He uses a computational rheology (computer simulation) to fuse those two rheologies together in an attempt to further the understanding of the rheology of cement paste and concrete. He uses a derivation of the flow equation based on the excessive stress theory and proposes a constitutive formula for the flow by extensively developing the Bingham model. Furthermore, he states that the relationship between the shear stress and the shear rate of the cement paste which includes phenomena such as softening, hardening, and hysteresis, can be simulated [3].

### **Rotating viscometer**

In a rotating viscometer, a cylindrical rotor (rotating element) is inserted into a specimen and is then rotated at a constant velocity by a motor. The principle of measurement by the rotating viscometer utilizes the rule that the rotating torque, i.e. the force to cause this rotation steadily, is proportional to the viscosity. When rotation reaches a steady state, the rotating torque caused by the viscosity balances with the rotating torque caused by the torsion of a twisting spring, and the torsion angle of the spring becomes proportional to the viscosity of the specimen, and is indicated by an index on the scale.

It is the simplest method and is commonly called a single-cylinder type rotating viscometer. Another type of rotating viscometer is called the co-axial double-cylinder type rotating viscometer, in which the specimen is filled into a space between the outer cylinder and the inner cylinder, either the inner or the outer cylinder is rotated to generate a state of laminar flow, and the viscosity is measured. There is also another type called a constant rotation torque method in which the rotational torque is controlled at a constant measured value.

Although the rotating viscometer is an excellent method in terms of physical principle, the range of viscosities able to be measured by each rotor is narrow and the continuity of measurement is lost when the rotor is changed. In order to cover a wide range to be measured, several types of rotors shall be needed. Moreover, the accuracy in measurement is guaranteed only for the full-scale measurement and errors in measurement at the low viscosity side may become large.

The report by the Committee for Research on a Mechanical Model of Fresh Concrete, Japan Concrete Institute (JCI), pointed out the following problems for rotating viscometers [4].

1. Laminar flow distribution is significantly disturbed by motion of large individual particles such as coarse aggregate.

2. In order to simulate the ideal laminar flow, it is necessary to scale-up the test equipment, and the experiment shall be done with a considerable volume of concrete.
3. For a concrete whose plastic viscosity is small and yield stress value is large, slippage occurs between the specimen and the cylinder.
4. Loss in torque generated on the bottom of the inner cylinder cannot be neglected in the experiments on concrete.
5. For a concrete whose plastic viscosity is small and yield stress value is large, as it is necessary to conduct measurements at a high rotation rate, changes of the properties of the specimen may occur easily due to the induced mixing motion.
6. As the inner pressure distribution is generated due to the self weight of the specimen, the stress condition varies depending on height in the container, and the friction resistance among individual particles may have significant impacts.
7. In actual test results, influences due to the folding point are significant and accordingly it is difficult to obtain a distinct yield stress value, and thus problems lie in the reproducibility of the data.

According to these characteristics, it is pointed out that measurement by the rotating viscometer may be limited to the material of more than 15 cm slump, and that adjustments may be needed even for the specimens within the limit.

Uhcikawa et. al. [5] found that, for a cement paste and a paste made of a non-hydraulic quartz powder of the same particle size, both of their yield stress values obtained by continuously applying a low shear rate, increase for 2 hours, and pointed out that coagulated structures are formed accompanied by particle settlement, such that the yield stress value increases. Park [6] has conducted extensive rheological analysis of cement pastes made of cement, fly ash, and slag, and additionally mixed with silica fume, by using a double cylinder rotating viscometer.

### **Vibrating viscometer**

The principle of measurement by the vibrating viscometer is as follows. When a shear rate ( $D_s$ ) is applied to one plate of two parallel plates holding a liquid in between, a shear stress ( $\tau$ ) or drag is generated in the other plate. The viscosity ( $\eta$ ) is equal to the rate of shear stress ( $\tau/D_s$ ) when the shear rate is continuously measured. Although the viscosity is constant even its shear rate changes for a Newtonian fluid, it varies depending on the shear rate for a Bingham fluid such as concrete. Therefore, for the yield stress value ( $\tau_0$ ) and plastic viscosity ( $\eta_p$ ), approximate values of these parameters can be obtained from equation Eq.(5) by continuously measuring shear rate and shear stress and by drawing a flow curve shown in Fig. 2.

$$\tau = \tau_0 + \eta_p D_s \quad \text{Eq.(5)}$$



The flowability of cement paste has been evaluated by obtaining the shear rate with a rotating viscometer based on the rotation number of the rotor inserted into the specimen, and the shear stress based on the rotation torque of the rotor. As the double cylinder rotating viscometer of high accuracy, has a short distance between the cylinders, and the range of torque to be measured is narrow, it is only applicable to cement pastes of low viscosity, or of high water-to-cement ratio, and it cannot evaluate the flowability of mortar or concrete containing aggregates.

Since the vibrating viscometer has a relatively narrow vibration range of the sensor plate, and uses a stress priority control method in which the driving current is set, it is able to perform measurements even when the shear rate is near zero and the accuracy in the measurement of the yield stress value is high. When a vibrating viscometer is used, the visco-elasticity for the mortar containing fine aggregate, having water-to-cement ratio of approximately 0.2, and using a high shear rate, can be measured.

In the vibrating viscometer, a response plate as shown in Fig.3, is inserted into the specimen, and is then vibrated by a driving current. Stress exerted in the response plate is proportional to the magnitude of the driving current,  $I$ , as shown in Eq.(6). The amplitude of the response plate is sensed as a voltage, which is converted into electric current and detected, and the shear rate  $D_s$  is obtained from its amplitude. Then, a continuous relationship between the shear rate,  $D_s$ , and the shear stress  $\tau$  is obtained as follows;

$$\tau \text{ (Pa)} = k \cdot B \cdot L \cdot I \quad \text{Eq.(6)}$$

(where,  $k$ : a constant,  $B$ : magnetic flux density (constant),  $L$ : length of coil (constant),  $I$ : driving current (A))

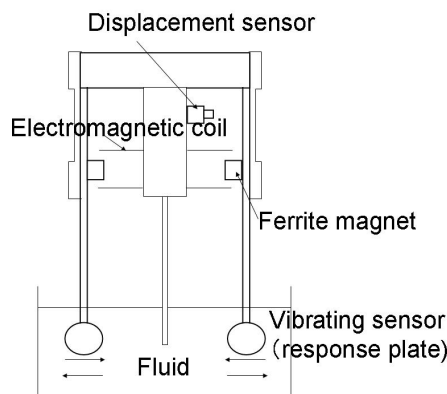

Fig.3 Schematic diagram of vibrating viscometer.

Uchikawa et al [7] [8] mixed three groups of different particle sizes, i.e. limestone powder of average particle size of 2  $\mu\text{m}$ , low heat of hydration cement of average particle size of 15  $\mu\text{m}$ , and cement made of residual

powder from the mill of average particle size of 40  $\mu$ m, into the mortar of the water-to-cement ratio of 0.2, s/c = 1.5, and investigated their flowability and strength development. Rheological parameters were measured by a vibrating viscometer, and flow curves were obtained for those with low water-to-cement ratios, and the yield stress value and plastic viscosity were able to be measured.

Therefore, the type of measurements described above mentioned would be difficult or impossible to obtain using a rotating and vibrating viscometer.

## **2. Rheology of cement systems with chemical admixtures**

The last state-of-the-art report on the issue of the interaction among chemical admixtures and concrete materials in the International Congress on the Chemistry of Cement, ICCC was authored by Collepardi and Ramachandran in the 9<sup>th</sup> congress, 1992 [9]. At that time, the most advanced superplasticizers were sulfonated naphthalenes and melamine formaldehyde condensates. The term superplasticizer means a cement dispersant achieving a higher dispersion of cement particles than traditional dispersants such as lignin sulfonates. In the 10<sup>th</sup> and 11<sup>th</sup> ICCC, although no plenary paper on this issue was published, one section was devoted to interactions between chemical admixtures and cement and the number of papers presented was 18 and 29 at the 10<sup>th</sup> and 11<sup>th</sup> congresses, respectively.

After the 9<sup>th</sup> ICCC, outstanding developments have been achieved by the invention of polycarboxylate-type superplasticizers with polyoxyethylene graft chains, PC [10], [11]. Ultra-high strength concrete up to 200 MPa, arbitrary control of slump life, concrete recovery systems and self-compacting concrete are examples that exploit this new technology. Regarding the working mechanisms, new concepts have been introduced such as the steric hindrance effect, adsorption amount per unit surface area of hydrates, adsorption equilibrium of superplasticizer with sulfate ions, the effect of the chemical structure of PC, and the effect of cement characteristics.

In this section, the effects of chemical admixtures on the fresh properties of cement-based materials and the interaction between them are reviewed. In the first half, recent developments in cement dispersants are summarized. In the second half, interaction mechanisms between dispersants and concrete materials are summarized.

### **2.1 Type and effect of chemical admixtures**

At first, recent circumstances of chemical admixtures in concrete production and research activities will be outlined. In the sections that follow, details of typical superplasticizers will be explained.

#### **1) Line up of recent chemical admixtures**

Chemical admixtures are classified in various categories by their chemical components and functions. The reason why typical chemical admixtures are listed here is that the understanding of these chemical admixtures is indispensable in discussing the interaction between superplasticizers and concrete materials such as cement, supplemental cementitious materials and aggregates.

**Polyol-type:** Starch derivatives such as gluconic acid are the main

component. Polyol-type admixtures are generally inexpensive and are used widely all over the world. In the US, this is the most popular water reducer. Polyol has set retarding effect. Attempts have been made to improve slump retention by adding gluconic acid when poly-naphthalene-condensate (PNS) is used as a main cement dispersant. However, these attempts have been ineffective. At present, slump retention is generally controlled by using a specific type of PC. The set delaying effect of gluconic acid is proportional to the dosage. Gluconic acid prolongs the induction period, but the strength development after setting is comparable to a system without gluconic acid.

**Polycarboxylate without graft chains:** Polymer of oxycarbonate. The dispersing effect is usually limited and this type of admixture is not widely used.

**Lignin sulfonate-type AE water reducer:** Most popular air-entraining (AE) water reducer. This product is a sulfonated lignin byproduct of paper manufacturing. Recently, due to changes in the paper manufacturing process, the supply of this material is decreasing. Lignin sulfonate has an air-entraining effect. Lignin sulfonate is often used in a mixture with gluconic acid. The water reducing performance is dependent on the dosage. Lignin originally contains some sugar components that retard the setting of cement. In order to avoid setting retardation, traditionally in Japan, the dosage of lignin sulfonate is fixed to be 0.25 mass % of cement. However, by applying a technique of ultrafiltration, the components causing set retardation can be eliminated. This specially treated lignin sulfonate can be added at higher dosages without retarding set and results in a higher degree of cement dispersion.

**Poly-beta-naphthalene sulfonate-type and poly-melamine sulfonate-type superplasticizers (PNS & PMS):** Raw materials for PNS and PMS are naphthalenes as a byproduct from coke production in the steel industry and melamines as a product of the petrochemical industry, respectively. These raw materials are polymerized by formaldehyde and sulfonated. They are produced in a molecular size that is suitable as a cement dispersant. PNS and PMS do not have a significant air-entraining effect. Both types of superplasticizers have poor slump retention in many cases. In Japan, the application of PNS is limited to factory production of concrete. PNS and PMS are not suitable for ready mixed concrete requiring a long slump life. PNS and PMS show incompatibility when mixed with polycarboxylate. The benzene ring is believed to interact with poly-oxethylene (POE) chains and spoil the dispersion performance.

**Polycarboxylate-type superplasticizer (PC):** PC is a dispersant invented in Japan in the 1980's [2] and is synthesized from petrochemical products. PC is a so-called comb-type dispersant as shown in Table 3 [12] and is

Table 3 Molecular structure of comb-type PC superplasticizers used in Japan [12].

Group	Molecular structure
I	$\begin{array}{c} \text{R}_1 \qquad \text{R}_1 \\   \qquad   \\ \text{H}-(\text{CH}_2-\text{C})_l-(\text{CH}_2-\text{C})_m-\text{H} \\   \qquad   \\ \text{C}=\text{O} \quad \text{C}=\text{O} \\   \qquad   \\ \text{OM} \quad \text{O}(\text{CH}_2\text{CH}_2\text{O})_n\text{R}_2 \\ (\text{R}_1=\text{H or CH}_3 \quad \text{R}_2=\text{CH}_3 \quad \text{M}=\text{Metalion}) \end{array}$
II	$\begin{array}{c} \text{H}-(\text{CH}-\text{CH}-\text{CH}_2-\text{CH})_m-\text{H} \\   \qquad   \qquad   \\ \text{O}=\text{C} \quad \text{C}=\text{O} \quad \text{CH}_2\text{O}-(\text{CH}_2\text{CH}_2\text{O})_n-\text{R}_1 \end{array}$
III	$\begin{array}{c} \text{R} \qquad \text{R} \qquad \text{R} \qquad \text{R} \\   \qquad   \qquad   \qquad   \\ \text{CH}-\text{CH}_2-(\text{C}-\text{CH}_2)_m-(\text{C}-\text{CH}_2)_p-(\text{Z})_r-\text{CH}_2-\text{CH} \\   \qquad   \qquad   \qquad   \\ \text{CH}_2 \quad \text{C}=\text{O} \quad \text{C}=\text{O} \quad \text{SO}_3\text{M} \\   \qquad   \qquad   \qquad   \\ \text{SO}_3\text{M} \quad \text{OM} \quad \text{O}(\text{CH}_2\text{CH}_2\text{O})_n\text{R} \quad \text{N} \quad \text{SO}_3\text{M} \\ (\text{R}=\text{CH}_3, \text{M}=\text{Na}) \end{array}$ $\begin{array}{c} \text{R} \qquad \text{R} \qquad \text{R} \qquad \text{R} \\   \qquad   \qquad   \qquad   \\ \text{H}-(\text{C}-\text{CH}_2)_l-(\text{C}-\text{CH}_2)_m-(\text{C}-\text{CH}_2)_p-(\text{C}-\text{CH}_2)_n-\text{H} \\   \qquad   \qquad   \qquad   \\ \text{C}=\text{O} \quad \text{C}=\text{O} \quad \text{Y} \qquad \text{X} \\   \qquad   \qquad   \qquad   \\ \text{OM} \quad \text{OR} \quad \text{O}(\text{CH}_2\text{CH}_2\text{O})_n-\text{R} \quad \text{SO}_3\text{M} \\ (\text{R}=\text{CH}_3, \text{H} \\ \text{X}=\text{CH}_3, \text{CH}_2-\text{O} \\ \text{Y}=\text{CH}_2, \text{C}=\text{O}) \end{array}$
IV	$\begin{array}{c} \text{---(A)}_l\text{---(B)}_m\text{---(C)}_p \quad (n > 60) \\   \qquad   \qquad   \\ \text{COONa} \quad \text{O}(\text{CH}_2\text{CH}_2\text{O})_n-\text{H} \quad (\delta + m + p = 10-20) \end{array}$
V	$\begin{array}{c} \text{R}_2 \\   \\ (\text{AO})_n \\   \\ \text{O} \\   \\ \text{C}=\text{O} \\   \\ \text{H}-\text{CH}_2-\text{C}-\text{CH}_2-\text{C}-\text{H} \\   \qquad   \qquad   \qquad   \\ \text{R}_1 \qquad \text{R}_1 \end{array}$ <p style="text-align: center;">(D)---Crosslinked point</p> $\begin{array}{c} \text{R}_1 \qquad \text{R}_1 \\   \qquad   \\ \text{H}-(\text{CH}_2-\text{C})_l-(\text{C}-\text{CH}_2)_m-\text{H} \\   \qquad   \\ \text{C}=\text{O} \quad \text{R}_1 \\   \qquad   \\ \text{O} \qquad \text{O} \\   \qquad   \\ (\text{AO})_n \end{array}$ <p style="text-align: right;">AO: Alkyleneoxide</p>

composed of three essential parts; a backbone of polyethylene, grafted chains of POE and carboxylic groups as adsorbing functional groups. By modifying these chemical structures, various properties such as dispersion performance just after mixing, slump retention, setting and so on can be controlled [13]. The details are explained in the next section.

PC usually has an air-entraining effect. The effect is known to be different depending on the mixing system, e.g. in the laboratory a much greater

amount of air is usually introduced easily and an anti-foaming-agent is often required but in real plants such excessive air is not entrained and in fact, an AE agent is used. The selection of this AE agent is an important point for the manufacturing because some types of PC drastically reduce the freezing/thawing resistance.

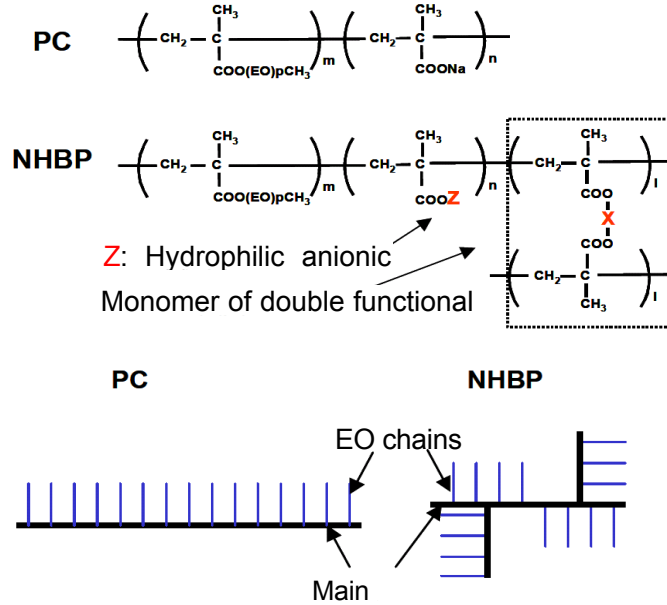

Fig. 4 Chemical structure and schematic image of traditional PC and new branched PC (NHBP) [14].

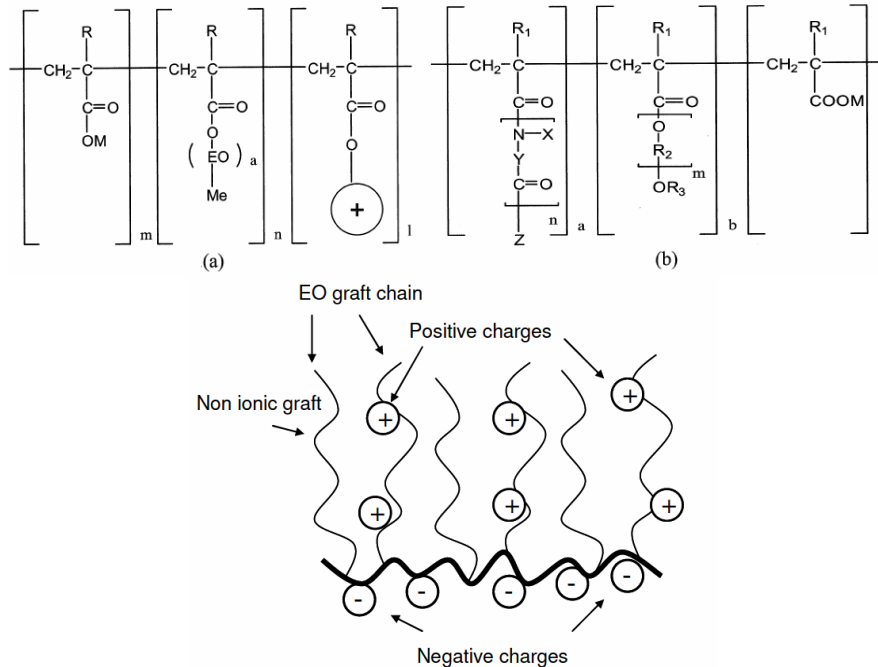

Fig. 5 Chemical structure and schematic image of new low-stickness type superplasticizers [11] [15].

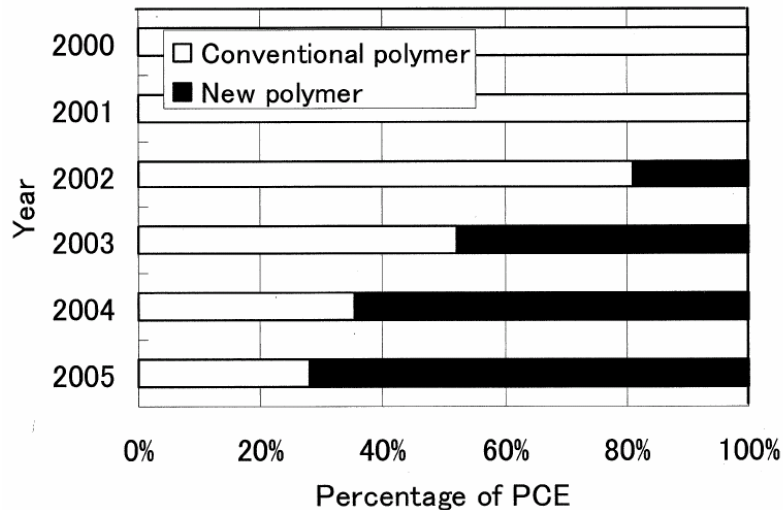

Fig. 6 Consumption volume percentage of total PC-based superplasticizers in Japan [11].

PCs listed in Table 3 are called 1<sup>st</sup> generation. These PCs have a potential to disperse cement particles perfectly. In addition to this function, ease of handling concrete is recently required, because concrete with a low  $w/c$  is "heavy" to handle. For this purpose, branched-type polymers and low stickiness type superplasticizers have been developed as shown in Fig. 4 [14] and Fig. 5 [11] [15], respectively. This PC can reduce apparent viscosity at a constant yield stress. In other words, when compared at the same slump, the concrete using this PC is easier to handle. Drastic changes of PC type in the Japanese market are shown in Fig. 6 [11]. Since 2002, PC has been moving to the 2<sup>nd</sup> generation.

**Mixed type:** In order to satisfy the diverse requirements of concrete producers such as low cost, moderate water reducing performance, and suitable slump life, several components are blended into one water reducer. A typical combination is polyol – lignin sulfonate – polycarboxylate – AE agent. Simultaneously, blending of several PCs of different characteristics has also become popular.

**Shrinkage reducing admixture:** By reducing the surface tension of water in capillary and gel pores, autogenous and drying shrinkage are decreased. The main component of a shrinkage reducing admixture is a nonionic molecule consisting of a lower alcohol with an alkylene oxide [16]. Superplasticizers act as a dispersant after adsorbing on cement particles. Conversely, a shrinkage reducing admixture works within the pore solution without adsorption on solid surfaces. Following their invention, development activities have continued [17]. One problem with this type of shrinkage reducing admixture is the control of air content and air bubble size distribution to avoid degradation by freezing / thawing.

One recent development of shrinkage reducing admixture is their application combined with expansive additives. Taking into account the temperature rise and the effect on mechanical behavior, a new design model to estimate the thermal expansion and relating cracking behavior has been proposed [18]. This technology can control the cracking caused by thermal, autogeneous, and drying shrinkage deformation effectively.

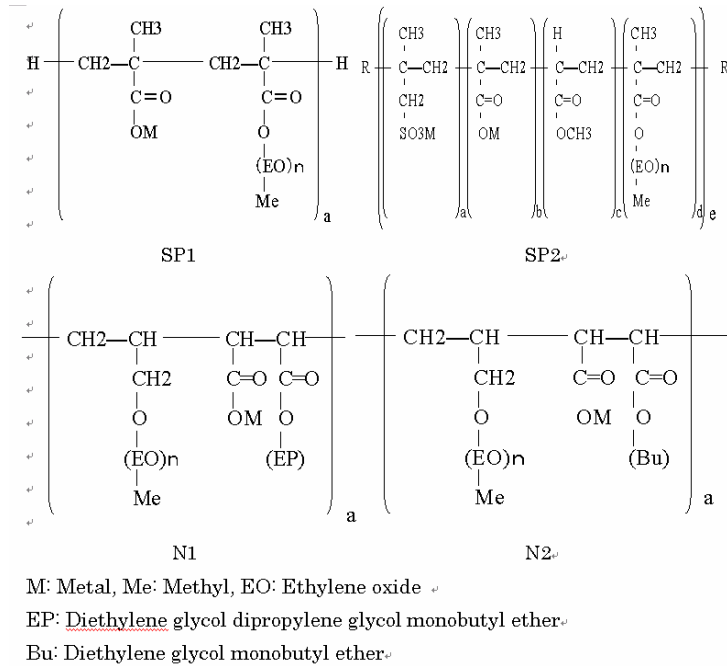

Fig. 7 Chemical structure of multi-function-type superplasticizer [20].

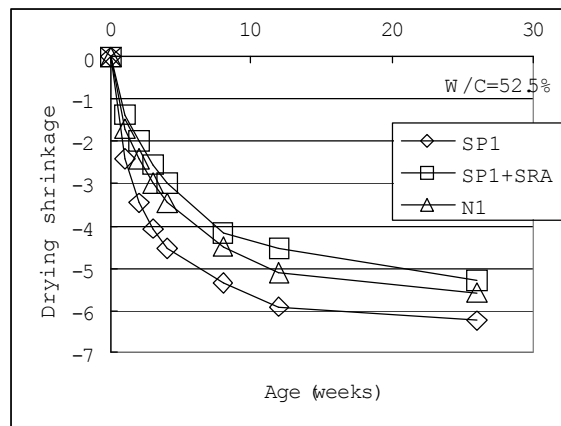

Fig. 8 Drying shrinkage reduction by multi-function-type superplasticizer [20].

**Multi-function-type superplasticizer:** A new type of superplasticizer (Fig. 7) that provides a reduction in drying shrinkage (Fig. 8) has recently been developed [19]. SP1 and SP2 in Fig. 7 are traditional PCs and N1 and N2 are multi-functional types. Some carboxylic groups are used to introduce a



shrinkage reducing functional component. The effect of this new superplasticizer is shown in Fig. 8 [20]. The characteristic point of this superplasticizer is the reduced amount of dosage compared to ordinary shrinkage reducing admixtures. With the similar dosage of typical PC, a 10 % – 20 % reduction of autogeneous and drying shrinkage can be achieved.

**Set retarder:** A recovery system of returned fresh concrete for addition to new concrete has been developed [21]. A suitable amount of set retarder is added into the returned fresh concrete and the hydration of cement is interrupted for as long as the user wants. In this technique, a strong retarder containing a phosphate group is typically used. When this returned concrete is used with new fresh concrete, another admixture is added to re-start the normal hydration of cement.

## 2) Chemical structures of PCs and performance

In this part, the relationship between the chemical structures of PCs and their performance will be described. Important factors are the length of graft chains, degree of polymerization, and the density of graft chains or carboxylic groups. Ota *et al.* [13] have summarized the effect of structural factors of PC on performance as shown in Table 4. Yamada *et al.* [22] also reported the effect of chemical structure on the rheological properties of cement paste at various W/C as shown in Fig. 9. A longer graft chain is preferable for high fluidity, especially at lower w/c. There is an optimum length of the trunk chain.

These behaviors should be considered from a mechanistic standpoint. A longer graft chain showed less fluidity retention in one study [22], which is in contradiction with the results shown in Table 4. Some other experimental results are also contradictory. The characteristics of PCs depend on the raw materials and the synthesis conditions. Therefore, the effect of the chemical structure of PCs on their performance can be different when the manufacturer is different although the basic structure and working mechanism are same. It is quite difficult to characterize the detailed chemical structure of these kinds of polymer mixtures by any advanced techniques of analysis. The chemical structures shown in Table 3 and Figs. 4, 5 & 7 are only estimations. This is one of the difficult points of the fundamental study of superplasticizers.

However, the basic mechanism is thought to be similar. Carboxylic groups have a role to adsorb on the solid surfaces at the position of  $\text{Ca}^{++}$  ion sites as shown Fig. 10 [13]. Graft chains generate steric hindrance effects to reduce the attractive forces responsible for the flocculation of cement particles and hydrates. The polymer remaining in the solution phase may also affect the dispersion in some way.

Table 4 Structural factors causing high dispersibility and retention of dispersibility [12].

Dispersibility	Structural factor	Relative chain length of trunk polymer	Relative graft length	Relative number of grafts
Low dispersibility and short dispersibility retention		Long	Short	Large
High dispersibility		Short	Long	Small
Long dispersibility retention		Shorter	Long	Large

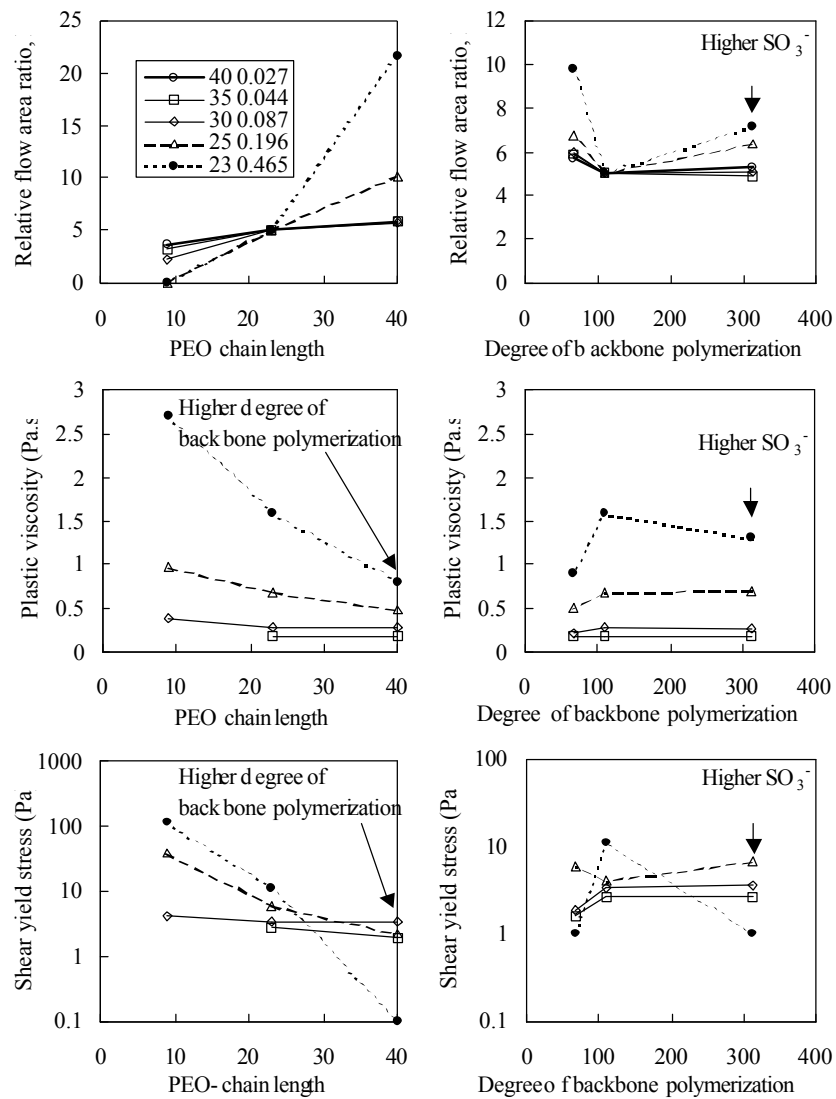

Fig. 9 The effects of chemical structure of PC on the rheological behavior of cement paste (Legend: W/C, dosage of PC) [22].

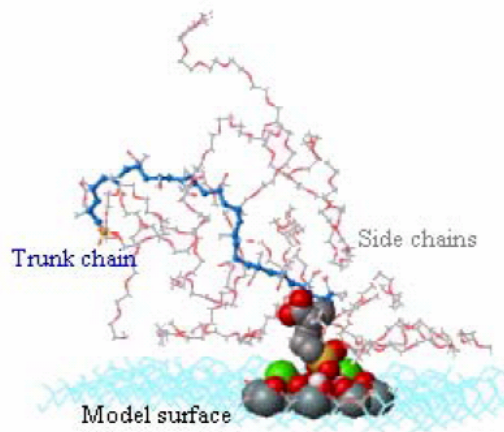

Fig. 10 Steric conformation of adsorbed PC at Ca site on model hydrate [23].

## 2.2 Mechanism of dispersion of cement by chemical admixtures

### (1) Fundamental dispersing force

Cement particles are thought to flocculate due to van der Waals forces [24]. There are three fundamental mechanisms of dispersion by cement dispersants. First is the lubrication by the adsorption of hydrophilic molecules such as polyol type water reducers. Second is the electrostatic force by the adsorption of sulfonated types such as PNS and PMS. The last one is the steric hindrance effect by graft chains of adsorbed PCs. The existence of the steric hindrance force was first indicated experimentally by Uchikawa et al. [25].

Theoretical calculation of interparticle potentials has been carried out by Yoshioka *et al.* [26] based on the theory of steric hindrance [27]. By the sum of potentials due to Van der Waals forces and steric hindrance effects, an interparticle potential was calculated as shown in Fig. 11 [28]. When a longer graft chain ( $n$ ) is used, stabilization by a large negative interparticle potential that causes flocculation approaches zero and strong flocculation can be avoided.

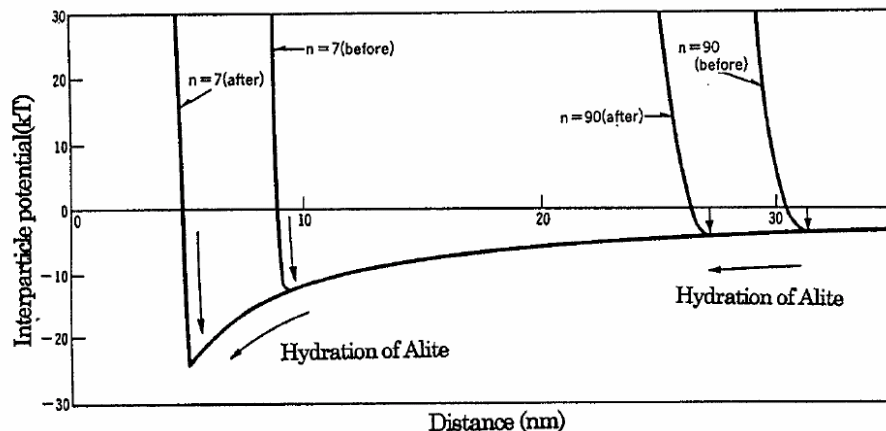

Fig. 11 Estimated interparticle potential when PC is used [28].

In addition to the dispersion just after mixing, the stability or fluidity retention is also important. Some mechanisms of fluidity change with elapsed time have been proposed. Hattori [29] proposed a physical flocculation in the system of PNS that occurs by random motion overcoming the electrostatic potentials between cement particles. In this study, the specific surface area change of cement in paste with elapsed time was measured by the Blaine method and no change was detected. Therefore, the effect of cement hydration was ignored. However, when the specific surface area was measured by the BET method [30], it increased and the effect of cement hydration must be taken into account.

Good slump retention of some PC may be achieved by delayed adsorption. By modifying its chemical structure, adsorption characteristics can be changed. There are some cases that fluidity increases with elapsed time when specific PCs such as the copolymer of maleic anhydride and POE-arylether are used. One possible mechanism is introduced next .

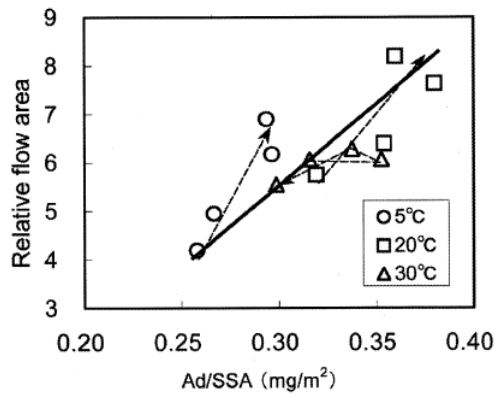

Fig. 12 Paste fluidity and adsorption amount of PC per specific surface area of hydrated cement (Arrows show the time variation during 2 h) [30].

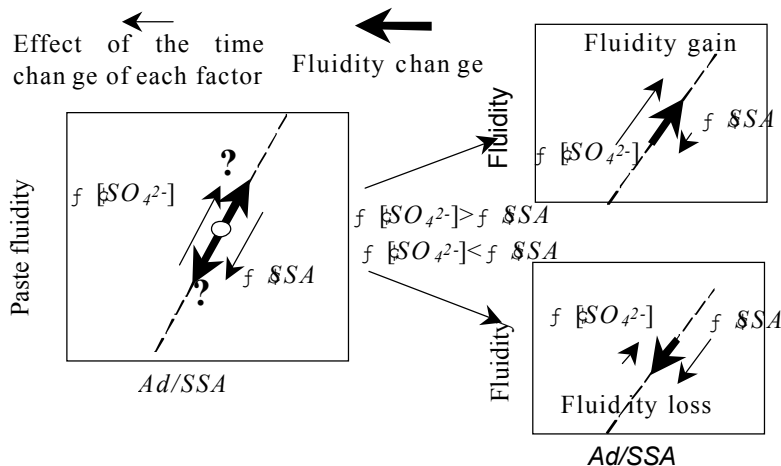

Fig. 13 Fundamental concept of the working mechanism of the time change of paste fluidity containing PC [23].

## (2) Adsorption amount per surface area

One simple explanation of the performance of superplasticizers is that the dispersing performance is proportional to the adsorption amount per surface area of hydrated cement, Ad/SSA. There are some examples supporting this hypothesis. When temperature is different, fluidity of cement paste containing PC is varied. This difference was explained by this parameter, Ad/SSA [31]. Depending on temperature and the age after mixing, fluidity of cement paste can vary widely as shown in Fig. 12 [31]. However, this variation can be explained by one parameter, Ad/SSA. The fundamental concept of this theory is shown in Fig.13 [23]. The fluidity is explained by two parameters, surface area of hydrated cement, SSA and adsorption amount of PC controlled by sulfate ion. Fluidity change with elapsed time is also explained by the time variation of these two parameters.

As time elapses, SSA increases and sulfate ion concentration,  $[SO_4^{2-}]$  decreases. These two phenomena affect the dispersing effect of PC in reverse manners. The change of SSA and  $[SO_4^{2-}]$  with elapsed time depend on the characteristics of cement, mixing procedure, and environmental conditions. The effect of  $[SO_4^{2-}]$  change on the dispersing effect of PC depends on the sensitivity of PC to  $[SO_4^{2-}]$ . By the balance of SSA and  $[SO_4^{2-}]$  changes and the characteristics of PC, the fluidity change with elapsed time is determined. When the effect of  $[SO_4^{2-}]$  change is greater than that of SSA change, fluidity increases and vice versa. This theory has been applied to the analysis of concrete slump.

Hydrated cement is composed of several phases such as ettringite, monosulfate, gypsum, portlandite, C-S-H, and clinker minerals. Each phase will adsorb PC differently [23]. One major phase for adsorption of PC is ettringite. Adsorption of PC on the solid phases is in equilibrium with sulfate ions. Assuming a Langmuir type adsorption equilibrium of PC, Eq. (7) is proposed [23].

$$N_{PC} = \frac{N_i \cdot K_{PC} \cdot [PC]}{1 + K_{PC} \cdot [PC] + K_{SO} \cdot [SO_4^{2-}]} \quad \text{Eq. (7) [23]}$$

where  $N_{PC}$  is the number of adsorbed PC on the surface of solid  $i$ ,  $N_i$  is the number of adsorption sites on the surface of solid  $i$  corresponding to the saturated adsorption amount of PC,  $K_{PC}$  is the constant of adsorption equilibrium of PC,  $K_{SO}$  is the constant of adsorption equilibrium of sulfate ion,  $[PC]$  is the molar concentration of PC,  $[SO_4^{2-}]$  is the sulfate ion molar concentration.

Based on this Eq. (7), slump variation during two hours for concretes made with 9 cements from different plants has been estimated as shown in Fig. 14 [23]. There is a positive relationship between concrete slump and  $N_{PC}$ . There are still some gaps among cements. However, the general

experimentally observed trend was reproduced by this theory.

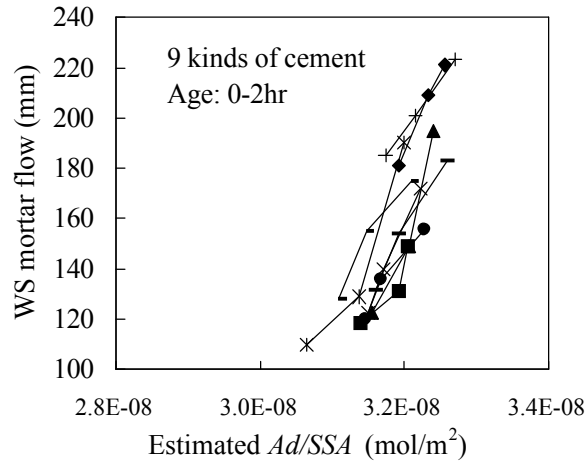

Fig. 14 Estimated  $Ad/SSA$  and WS mortar flow [23].

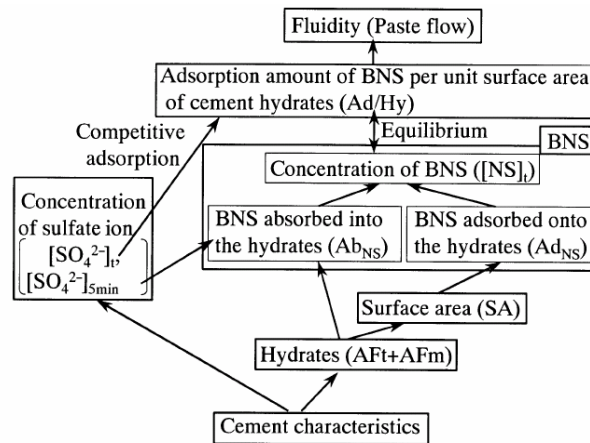

Fig. 15 Modeling the working mechanism of PNS [38].

This parameter is also effective in the case of PNS. PNS is well known for its delayed addition effect [32, 33]. The fluidity is much higher when PNS is added into mixed cement paste than when PNS is added in mixing water and mixed with cement. This effect can be explained by the absorption of PNS into initial hydrates produced just after mixing [34]. Some other explanations have also been proposed [35, 36]. This absorption is known to be competitive with sulfate ions [37]. Recently Nakajima *et al.* have summarized these concepts and proposed a comprehensive model [38]. The working mechanism is shown in Fig. 15 [38]. In this model, the competitive adsorption equilibrium between sulfate ions and PNS on hydrated cement is also considered.

For the modeling of PNS, it is necessary to estimate the adsorption amount. However, it is difficult to estimate it directly. In the model, adsorbed PNS on hydrates is in equilibrium with PNS and sulfate concentrations in the

solution phase. Based on this assumption, constants in Eq. (7) were determined for PNS and  $N_{PNS}$  (corresponding to  $\theta_{NS}$  in Fig. 16) was estimated. The relationship between paste flow and the calculated adsorption amount PNS per surface area of hydrated cement is shown in Fig. 16 [38]. In these experiments, various types of portland cement were used. There is a linear correlation between flow and the calculated adsorbed PNS, and it is suggested that this theory can explain the working mechanism of PNS.

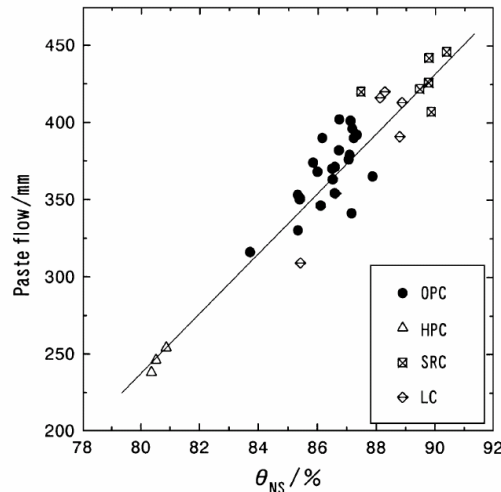

Fig. 16 Relationship between calculated adsorbed PNS and paste fluidity [38] (OPC: ordinary portland cement, HPC: high early strength cement, SRC: sulfate resistant cement, LC: low heat cement of low  $C_3A$  content).

### (3) Evaluation of the fluidity performance of cement and superplasticizers

In order to evaluate the fluidity performance of cement and superplasticizers, some standard procedure for testing is preferable. There are some important factors to consider. One is the use of an adequate amount of powder and the other is suitable mixture proportions, depending on the performance of the superplasticizers [39]. A discussion on “standard” cement and “standard” superplasticizer is explained.

The basic relationships between PC dosage and fluidity of concrete and mortar were examined as shown in Fig. 17 [39]. Concretes having  $w/c$  of 0.55, 0.40, and 0.30 were mixed with PC and several types of sand were used. Concrete slump, flows of wet screened mortar from the concrete and of separately mixed mortar of the same mixture proportions were measured. Usually one estimates the positive relationships between PC dosage and fluidity in every mixture. However, only in the case of  $w/c = 0.40$  were the expected relationships obtained. In some cases at  $w/c = 0.55$  or 0.30, PC did not affect the fluidity. In the case of  $w/c = 0.55$ , the powder content was insufficient and the workability of concrete was poor. Because of this, the deformation of concrete was not smooth and the effect of PC addition was

not detected. At low W/C, because the PC used was designed to be used around  $w/c = 0.40$  or higher, PC is thought to be sensitive to mixing conditions in this lower  $w/c$  and the performance is thought to be affected by slight differences in the mixing procedures.

In order to improve these factors, at higher  $w/c$ , limestone powder was added and at lower  $w/c$ , an appropriate PC in the range of the test was adopted. By these changes, in every case, PC addition was observed to effect the fluidity of the mixture. In each case of  $w/c$ , Ad/SSA shows a proportional relationship with fluidity as shown in Fig. 18 [40] and this means the fluidity of concrete or mortar is controlled by the dispersion of hydrated cement. In Fig. 19 [39], estimated Ad/SSA based on Eq.(7) and

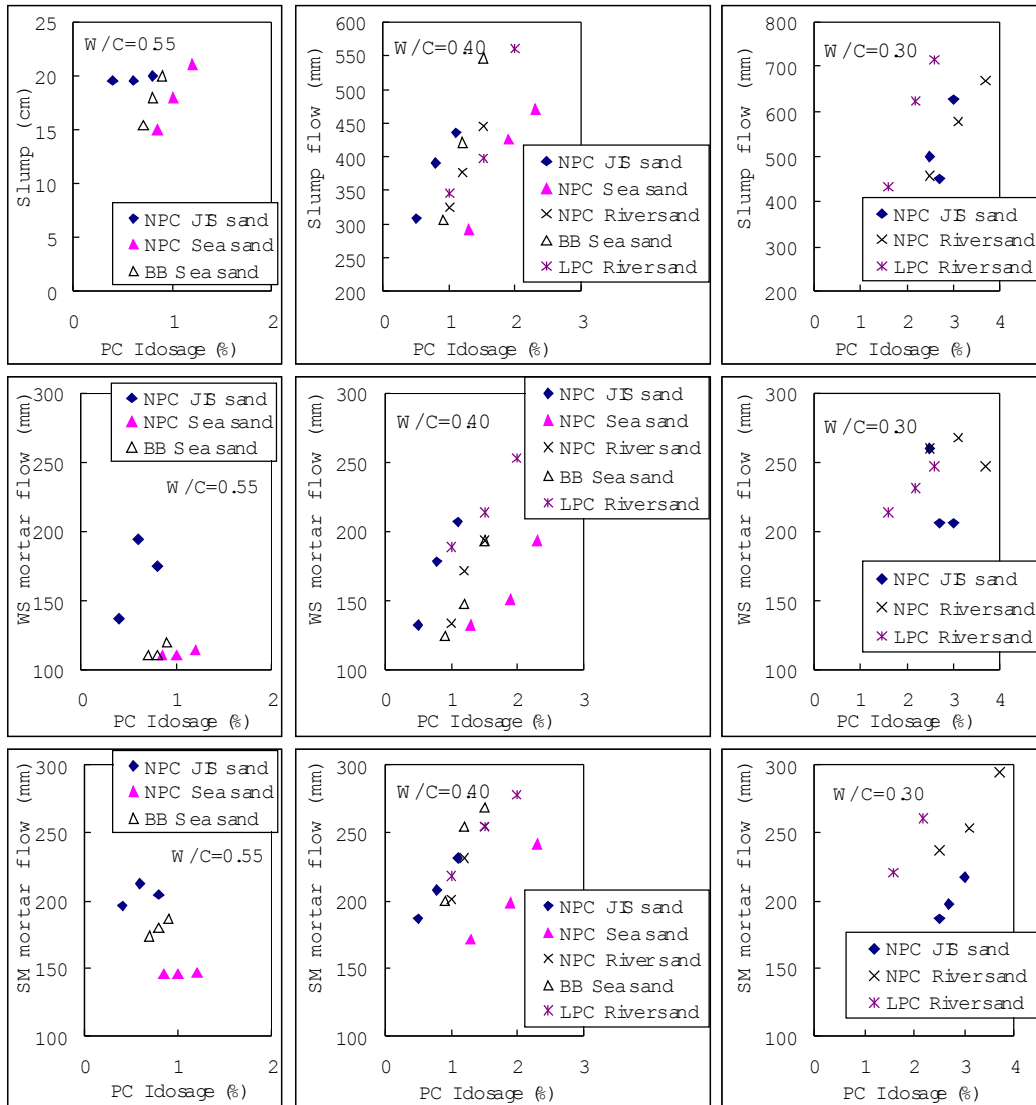

Fig. 17 Relationship between fluidity (concrete slump, wet screened mortar flow, and separately mixed mortar flow) and PC dosage at various W/C [39]. (NPC: Ordinary Portland cement, BB: 50% Blastfurnace slag cement, LPC: Low heat Portland cement)



the flow of separately mixed mortars is shown. There are linear relationships between estimated Ad/SSA and flow and this result indicates that the flow can be explained by this parameter.

Judging from this result, there is no universal testing method of cement and superplasticizer compatibility and no standard cement and superplasticizer but there are some general requirements for testing. One is an adequate amount of powder content in the mixture to achieve good workability. In the US and Japan, the strength class of the cement has not been introduced. However, for concrete of general strength, adequate powder content is indispensable for good workability of concrete [32]. For this requirement, a relatively low strength cement is preferable to use. Another point is the w/c level suitable for the superplasticizer testing.

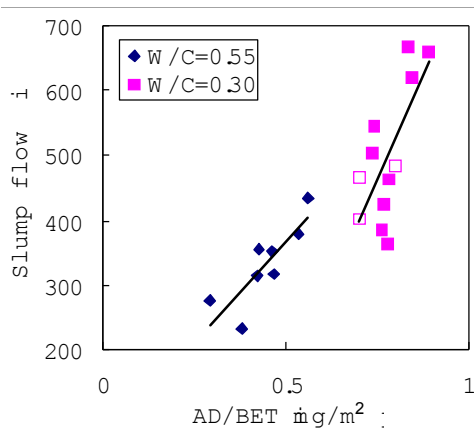

Fig. 18 Adsorption amount of PC per surface area of hydrated cement and slump flow [39].

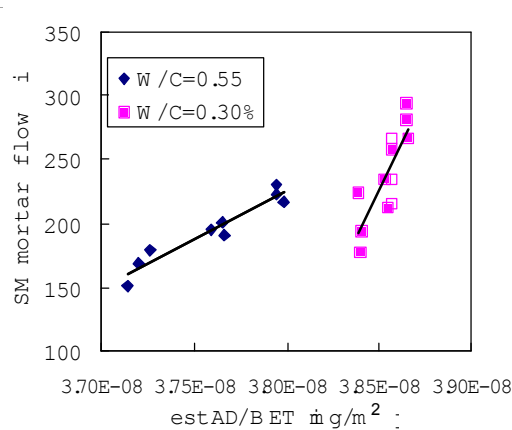

Fig. 19 Estimated adsorption amount of PC per surface area of hydrated cement and flow of separately mixed mortar [39].

## 2.3 Compatibility between cement and chemical admixtures

### (1) Examples of compatibility problems

As shown in Fig. 9, selection of a rheological index affects the analysis of the compatibility between cement and chemical admixtures. For example, the effect of PC is different in relative flow area and plastic viscosity. Yamada *et al.* [22] examined the relationship between paste fluidity and superplasticizer dosage as shown in Fig. 20. In these experiments, six kinds of cement and six kinds of superplasticizers from Japan and France (PNS, PMS and four PCs) were used. As shown in Fig. 20 [22], the same relative flow area can be obtained by different combinations. In order to distinguish them, two parameters are introduced.

In Fig. 21 [22], a schematic diagram of the relationship between superplasticizer, SP, dosage and relative flow area as an index of fluidity is

illustrated. SP affects the flow beyond a critical dosage. Above the critical dosage, SP increases the relative flow area linearly in some range and the effect is saturated over the saturation dosage. The slope of relative flow area increase against SP dosage is named as the dispersing ability. It is meaningful to point out that the same relative flow area can be obtained by different combinations of critical dosage and dispersing ability. Therefore, the comparison of relative flow area seems not appropriate. These two parameters for combinations of cement and superplasticizers were analyzed in correlation with cement characteristics.

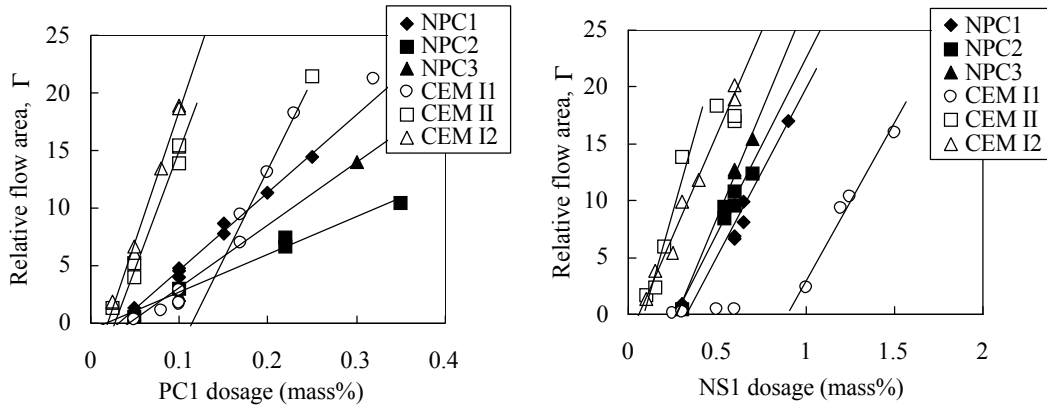

Fig. 20 SP dosage and fluidity of cement paste [22].

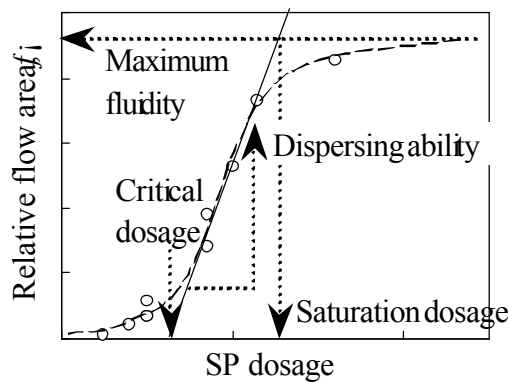

Fig. 21 Critical dosage and dispersing ability [22].

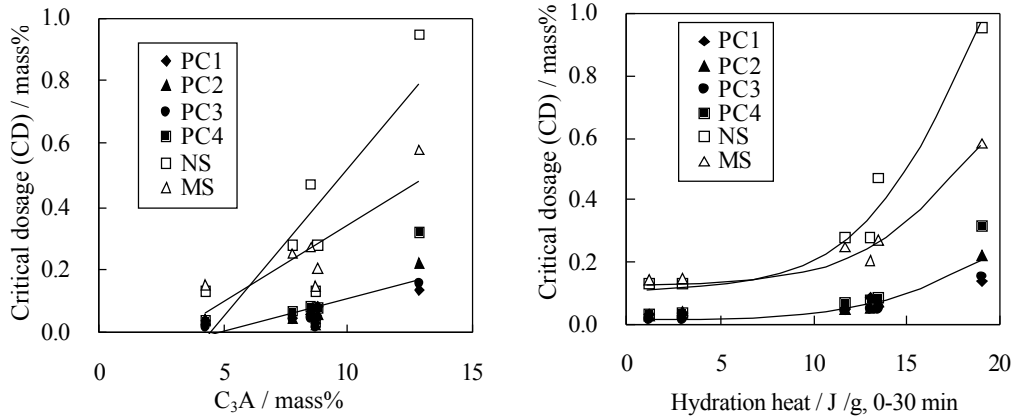

Fig. 22 C<sub>3</sub>A amount or hydration heat and critical dosage [22].

By multiple correlation analysis, among various cement characteristics, C<sub>3</sub>A amount was detected to have a significant correlation with critical dosage as shown in Fig. 22 [22]. C<sub>3</sub>A is expected to affect the amount and surface area of hydrates produced at early ages after mixing. The reactivity of C<sub>3</sub>A is affected by various factors. The amount of C<sub>3</sub>A by Bogue calculation itself may not be so accurate. Therefore, in order to evaluate the reacted amount of C<sub>3</sub>A accurately, the hydration heat was detected for 30 min after mixing by a micro-calorimeter. The correlations between hydration heat and fluidity are shown in the right graph of Fig. 22 [22]. Better positive correlations are obtained as expected. Critical dosage corresponds to the surface area of hydrates produced after mixing.

Regarding dispersing ability, the soluble alkali amount that corresponds to the amount of alkali sulfate in the cement showed a negative correlation, but the tendency was not so clear. Therefore, the effect of alkali sulfate was checked separately.

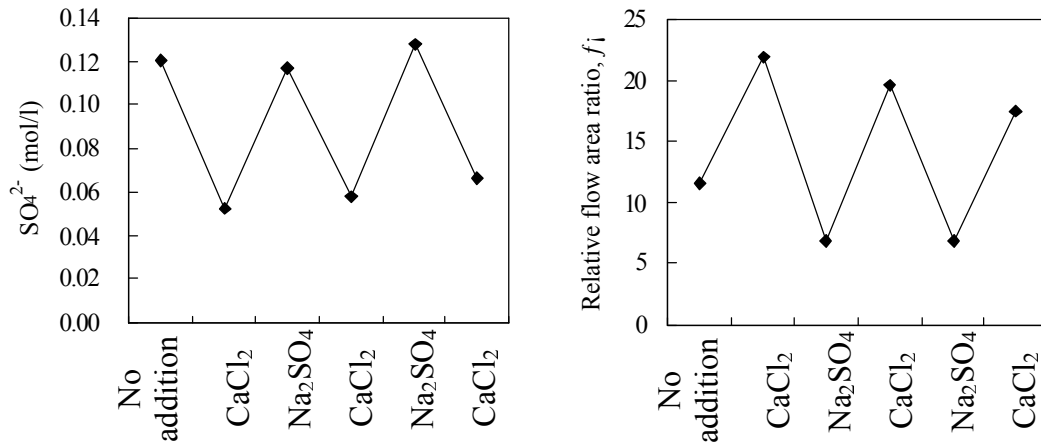

Fig. 23 Effects of salt addition on sulfate concentration and fluidity [42].

## (2) Effect of alkali sulfate on PC

The effect of alkali sulfate was first reported by Ohno *et al.* [41]. After several research studies, Yamada *et al.* [42] published a comprehensive study on the effect of sulfate ion on the adsorption behavior of PC. In order to control the sulfate ion concentration,  $\text{CaCl}_2$  and  $\text{Na}_2\text{SO}_4$  were added repeatedly to mixed cement pastes. The results are shown in Fig. 23 [42]. By the additions, the sulfate ion concentration was modified repeatedly. With the change of sulfate ion concentration, fluidity of cement paste was changed. The relationship between sulfate ion concentration and PC adsorption is shown in Fig. 24 [42]. There is a negative linear correlation indicating PC adsorption is controlled mainly by the sulfate ion concentration. This is one reason why low alkali cement shows higher fluidity performance. These experimental data suggest that PC is in an adsorption equilibrium with sulfate ions.

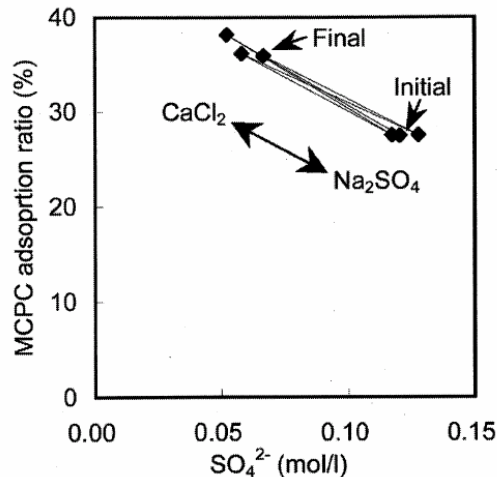

Fig. 24 The relationship between sulfate ion concentration and PC adsorption [42].

## (3) Tolerant PC to sulfate ion ratio

The sensitivity of PC to sulfate ion concentration is one of the reasons for incompatibilities between cement and PC. The alkali amount in cement usually depends on the raw materials and is not easily controlled. Therefore, it is convenient if a PC chemical structure that is tolerant to sulfate ions can be found.

Sulfate ion affects the adsorption of PC. Therefore, a PC with a higher adsorbing ability should perhaps be effective in providing a tolerance to the fluctuation of sulfate ion concentration. In Fig.25, the effect of carboxylic group ratio in the trunk chain on the fluidity decrease accompanying a sulfate ion increase is shown [43]. Polymers having more carboxylic groups are less affected by sulfate ions. A higher number of carboxylic groups in a trunk chain means a higher adsorbing ability, resulting in the higher tolerance to the fluctuation of sulfate ion.

It is possible to make extreme PCs having a very high adsorbing ability [44]. There are then no effects of sulfate ion, within the range normally encountered in cements. However, an excess amount of carboxylic groups result in a higher surface area of hydrates. Carboxylic groups have an acceleration effect on  $C_3A$  hydration at early ages after mixing with water. There is thus an optimum range of carboxylic group ratios. It is also possible to control adsorbing ability by reducing the number of graft chains. Of course, because the graft chains are the origins of the steric hindrance effect, there must be an optimum range. If the density of graft chains is too high adsorption of the steric polymer can be hindered.

A PC having a strong adsorbing ability is generally more tolerant for the fluctuation of sulfate ion concentration, but is usually inappropriate for fluidity retention because it does not remain in the solution phase. For this reason, a kind of PC suitable for fluidity retention is combined. Although the detailed mechanism is not clear, there are appropriate mixture compositions SPs that are sulfate ion tolerant while providing fluidity retention [35].

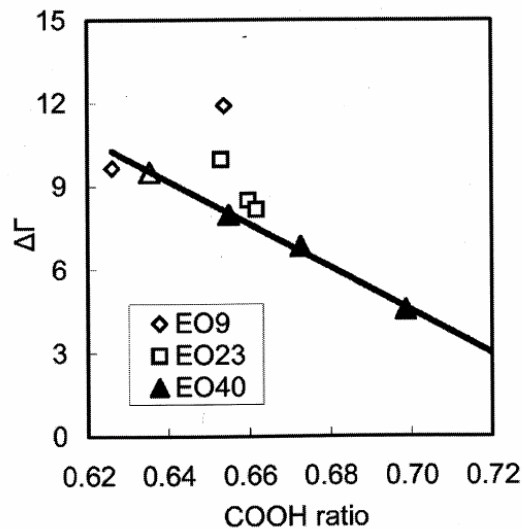

Fig. 25 The effect of carboxylic group ration in a truck chain on the effect of sulfate ion [44].

#### (4) PNS

In the case of PNS, there are two important factors that have been mentioned previously. One is the absorption of PNS with sulfate ion onto hydrates and the adsorption equilibrium with sulfate ion. The absorption can be avoided by delayed addition and by the increase of sulfate ion concentration just after mixing. The sulfate ion concentration can be increased by an addition of alkali sulfate or by increasing the ratio of hemihydrate to gypsum. These effects are shown in Fig. 26 [46]. By the delayed addition and by the addition of alkali sulfate, the critical dosage was

reduced, resulting in higher fluidity at a lower dosage of PNS. When alkali sulfate is added into mixed cement paste, the sulfate ion concentration is increased and less PNS was adsorbed by the cement hydrates and the fluidity decreased.

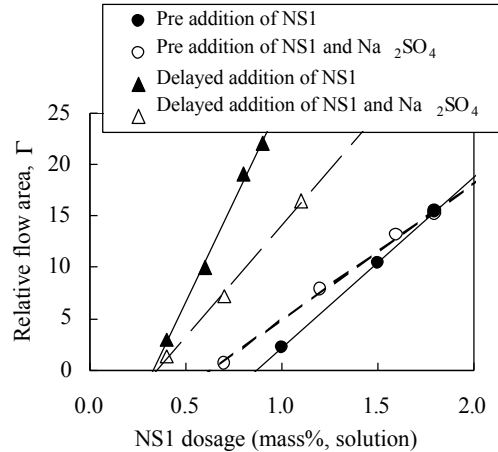

Fig. 26 The effect of delayed addition and alkali sulfate addition on the performance of PNS [46].

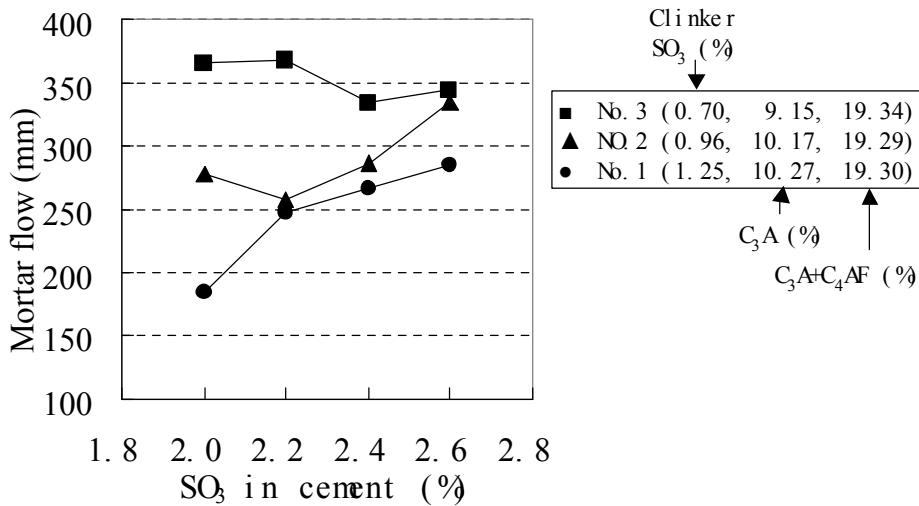

Fig. 27 Effect of  $\text{SO}_3$  content in cement on the fluidity of mortar containing PC [47].

## (5) Effect of cement characteristics

### 1) Sulfate in cement

Sulfate in cement exists mainly as alkali sulfate, gypsum, hemihydrate and anhydrite. The role of  $\text{SO}_3$  in cement is the suppression of rapid hydration of  $\text{C}_3\text{A}$ . In order to achieve this purpose, although the  $\text{SO}_3$  content is usually controlled in cement production,  $\text{SO}_3$  from calcium sulfate should be controlled because the effect of  $\text{SO}_3$  from alkali sulfate is limited compared

to that from calcium sulfate.

In Fig. 27 [47], the effect of  $\text{SO}_3$  content on the fluidity of mortar containing PC is shown. In the case of 9 % of  $\text{C}_3\text{A}$  and 0.70 % of clinker  $\text{SO}_3$  (majority exists as alkali sulfates), 2.0 % of  $\text{SO}_3$  in cement is adequate to suppress the hydration of  $\text{C}_3\text{A}$ . When  $\text{C}_3\text{A}$  and clinker  $\text{SO}_3$  contents increase to 10 % and 1.0 %, respectively, a high flow value is obtained. The flow of cement is lower at 2.0 % of  $\text{SO}_3$  in cement than in the former case. With the increase of  $\text{SO}_3$  by the addition of gypsum, the flow increases and this means an adequate amount of calcium sulfate is required to suppress the initial hydration of  $\text{C}_3\text{A}$ . At 2.6 % of cement  $\text{SO}_3$ , the flow recovers to the same level as the former case. When clinker  $\text{SO}_3$  increases more to 1.3 %, the flow was less but gypsum enhanced the fluidity also in this case.  $\text{C}_3\text{A}$  has a negative effect on the performance of superplasticizer. However, by the optimization of sulfate composition, adequate fluidity is possible.

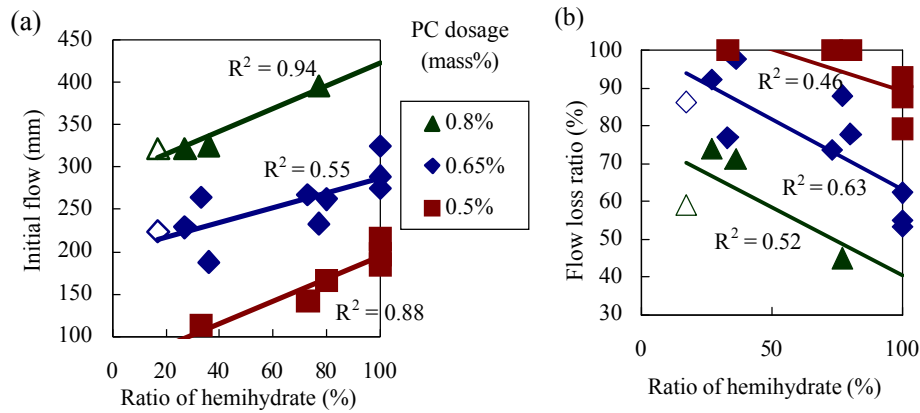

Fig. 28 Ratio of hemihydrate and initial flow (a) and flow loss ratio (b) [48].

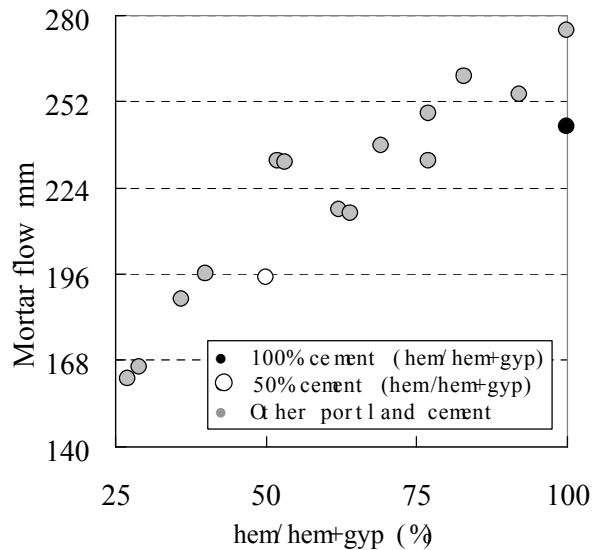

Fig. 29 The effect of hemihydrate ratio on the fluidity of mortar containing PC [47].

When  $\text{SO}_3$  in cement is controlled as calcium sulfate, the next point is the form of it. Generally, hemihydrate is preferable for PC and PNS. When the amount or ratio of hemihydrate increases, the performance of PC is enhanced. One example is shown in Fig. 28 [48]. In this investigation, cement was made from the same clinker and cement  $\text{SO}_3$  content was controlled in a real cement plant. This means the calcium sulfate content is controlled as constant. The ratio of hemihydrate was modified by changing the milling temperature. Fluidity of cement was measured by the flow of a mortar having  $w/c$  of 0.37 and PC. With the increase of hemihydrate ratio, fluidity increases. A higher hemihydrate ratio is also preferable for fluidity retention. At a higher hemihydrate ratio, fluidity loss decreases. In Fig. 29 [47], another example of the effect of hemihydrate on the fluidity of mortar containing PC is shown. A higher ratio of hemihydrate is preferable for the higher dispersing performance of PC.

## 2) $\text{C}_3\text{A}$ content and reactivity in cement

The effect of  $\text{SO}_3$  explained above has close correlation with the content and reactivity of  $\text{C}_3\text{A}$  because sulfate suppresses the reaction of  $\text{C}_3\text{A}$ . In other words, the reacted amount of  $\text{C}_3\text{A}$  is the essential parameter determining the surface area of hydrates that controls the most important parameter  $\text{Ad}/\text{SSA}$ .

The content and reactivity of  $\text{C}_3\text{A}$  can be diverse even if the  $\text{C}_3\text{A}$  content calculated by Bogue's equation is kept constant because there are some factors affecting  $\text{C}_3\text{A}$  content other than chemical composition of major elements. Important factors are  $\text{MgO}$  content, cooling speed, and potassium content, for example.

When  $\text{MgO}$  content in clinker is high,  $\text{C}_4\text{AF}$  content increases and  $\text{C}_3\text{A}$  content decreases and this is beneficial to the fluidity.

When the cooling speed from the liquid phase at high temperature is fast, producing a smaller clinker, the formation ratio of  $\text{C}_3\text{A}$  to  $\text{C}_4\text{AF}$  decreases and this is also beneficial to the fluidity. In Fig. 30 [39], one example is shown. From raw materials having the same chemical composition, clinkers were made by different cooling speeds. The  $\text{C}_3\text{A}$  content was quantified by an XRD/Rietveld method. As shown in Fig. 30, a lower content of  $\text{C}_3\text{A}$  results in higher fluidity. Another factor of cooling speed was also pointed out in this study. That is the morphology of the interstitial phase. By rapid cooling, the texture becomes finer. This phenomenon can be detected by measuring the crystallite size of  $\text{C}_4\text{AF}$ . At constant  $\text{C}_3\text{A}$  content, with the decrease of crystallite size of  $\text{C}_4\text{AF}$ , the fluidity increases.



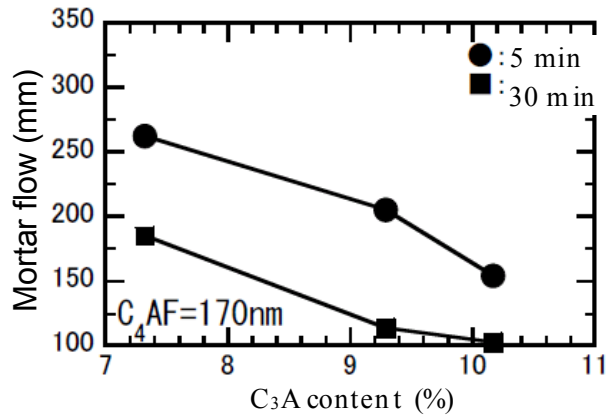

Fig. 30 C<sub>3</sub>A content and the fluidity of mortar containing PC [49].

Alkali is another factor affecting the reactivity of C<sub>3</sub>A [49]. The available amount of alkali associating with C<sub>3</sub>A is determined by the balance of alkali and SO<sub>3</sub> contents in the clinker. When the clinker is rich in potassium and relatively poor in sulfate, potassium is dissolved in the C<sub>3</sub>A phase and increases the reactivity of C<sub>3</sub>A. This situation is a disadvantage for the fluidity. In Fig. 31 [48], the effect of the SO<sub>3</sub>/alkali molar ratio on the fluidity of mortar containing PC is shown. In this case, alkali content in the clinker was kept constant. A higher SO<sub>3</sub>/alkali content is preferable for fluidity retention as well as fluidity just after mixing.

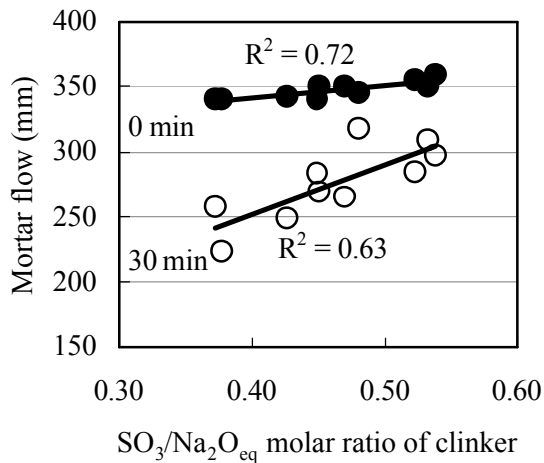

Fig. 31 Effect of SO<sub>3</sub>/Na<sub>2</sub>O<sub>eq</sub> ratio of clinker on the fluidity of mortar containing PC [48].

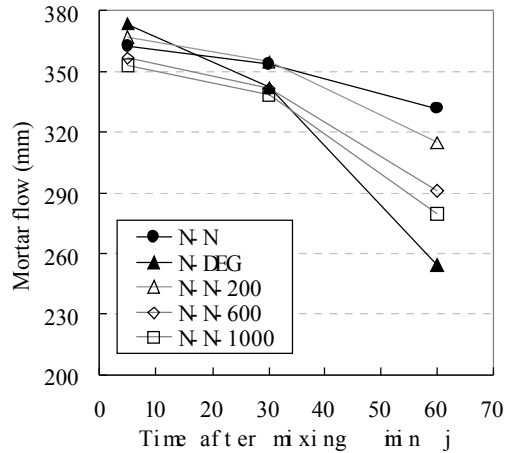

Fig. 32 The effect of DEG addition on the fluidity of mortar containing PC [51].

Reactivity of  $C_3A$  is also affected by water spray during the milling process or aeration during transportation and storage [46] [48]. By these processes, the reactivity of  $C_3A$  decreases. This change is generally preferable for PNS because the absorption amount into initial hydrates decreases. In the case of PC, it depends on the balance of the effects on surface area of initial hydrates and sulfate ion concentration. By the reduction of  $C_3A$  reactivity, sulfate ion consumption decreases and this may lead to an increase in sulfate ion concentration just after mixing.

Recently the effect of grinding agents on the initial hydration was reported as related to the performance of PC [51]. In Fig. 32 [51], the effect of di-ethyleneglycol, DEG, on the fluidity of mortar containing PC is shown. Initial flow just after mixing is similar. However, as time elapses after mixing, the flow decrease is more in the case where a greater amount of DEG is added. By the analysis, DEG activates the reactivity of  $C_3A$  just after mixing by interaction with  $Ca^{++}$  ions. In order to reduce the effect of DEG, milling at a higher temperature is preferable and this condition is also preferable to obtain a higher ratio of hemihydrate to dihydrate.

## (6) Other effects

### 1) Combination of Class C fly ash and retarder

Sandberg *et al.* [52] reported an incompatibility phenomenon caused by a specific combination of concrete materials, *i.e.* undersulfated ordinary portland cement, Class C fly ash, and a kind of water reducer having a set retarding effect. In this specific combination,  $C_3A$  hydrated abnormally and the hydration of  $C_3S$  was delayed significantly. According to this study, by the increase of  $SO_3$  level in cement, normal setting was obtained.

Fly ash is known to have a retarding effect [53]. Yamada *et al.* [54] studied a similar combination of materials, *i.e.* OPC having 2.5 % of  $SO_3$ , Class C fly ash having 9 % of  $C_3A$  and 40 % replacement of OPC, and a set of chemical

admixtures including a strong phosphate type retarder. In this study, an abnormal hydration peak of  $C_3A$  was also detected by compressive strength measurements of concrete and by micro-calorimetry. The hydration of  $C_3S$  was delayed significantly. The delay of hardening was in the range of several days and after the restart of the hydration of  $C_3S$ , the strength development was normal. Based on the analysis, the initial hydration of  $C_3A$  was not controlled effectively because of the increase of effective  $C_3A$  content brought about by the high replacement level of Class C fly ash and the effect of retarders “capturing”  $Ca^{++}$  ions from the solution phase. With the lack of an adequate amount of sulfate and  $Ca^{++}$  ion supply,  $C_3A$  is thought to react with an abnormally high activity and this results in the delay of  $C_3S$  hydration.

## **2) Clay minerals in aggregate**

Clay minerals such as montmorillonite affect the performance of SPs, especially their fluidity retention. Polyether graft chains can be caught in the interlayers of clay minerals and this results in the poor fluidity [55] [56].

### **3. Rheology of Self-compacting concrete**

Self-compacting concrete was developed in 1988 at the concrete laboratory in the University of Tokyo by Okamura, Maekawa, and Ozawa [57] [58]. Self-compacting concrete is concrete made of conventional constituents, which flows and fills every corner of the form by action of its self weight without compaction by vibrators. The effectiveness of the self compaction was proven through a comparative experiment between a conventional slump concrete and a self-compacting concrete both poured into a model formwork with many densely set rebars, and excellence in constructability achieved by the self-compacting concrete was confirmed.

Constraints given in the development of the self-compacting concrete were, i) the maximum size of coarse aggregate being about 20 mm, ii) the minimum spacing of rebars being larger than the maximum size of coarse aggregate, and iii) the cover between the form and the rebar being about the same as the size of coarse aggregate; the goal is to develop a concrete that can be poured while meeting all three constraints. The key point of the technology is how to pass the fresh concrete containing coarse aggregate of 20 mm particle size through the narrow spacing between rebars without material segregation, that is to provide the gap passing capability. By lowering the  $w/cm$  (including cementitious materials) in order to provide the self-compactibility, performance characterized by high strength, improved resistance to material transfer in concrete, and less bleeding are given to the concrete with few initial flaws, resulting in a high performance concrete.

Technical issues of self-compacting concrete are the following three points [59] [60].

- Mix design method
- Test method for the self-compactibility
- Development of a new high range AE water-reducing admixture

Application of the self-compacting concrete to the actual site has become popular in Sweden, Belgium, the Netherlands, and France rather than in Japan.

#### **3.1 Mix design of SCC**

Fig.33 shows an image on the self-compactibility of fresh concrete, focusing on the mechanism of passing through the gap. By limiting the amount of coarse aggregate, blocking phenomenon among coarse aggregates during passing through the gap is controlled. In addition, by reducing the amount of fine aggregate in the mortar part and making the water-to-powder ratio low, increase in resistance to shear deformation of the mortar caused by closely-packed coarse aggregate is controlled, the characteristic of moderate pressure transmission is strengthened, and thus the self-compactibility is enhanced.

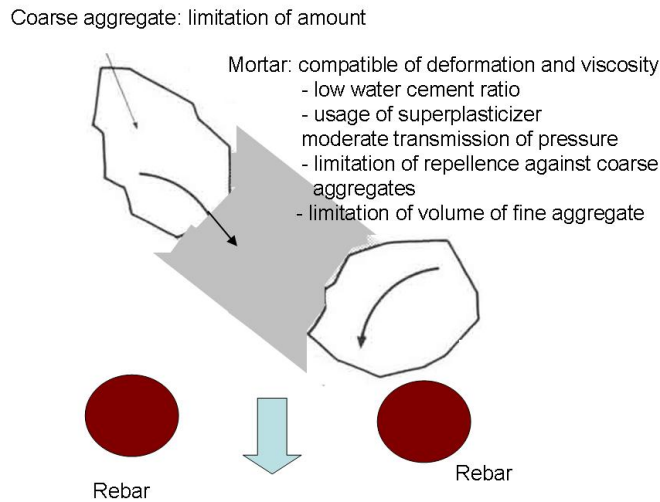

Fig.33 An image on the self-compactability of fresh concrete, focusing on the mechanism of passing through the gap [60].

Specifically, as shown in Fig.34, coarse aggregate holds 50% of total apparent volume, that is approximately 30% of total concrete volume. In the mortar part consisting of water, cement with admixtures, and fine aggregate, the upper limit of the volume of fine aggregate is set as approximately 40 %. A method of mixture proportioning was established such that self-compactability is achieved due to appropriate deformability and viscosity of the mortar part provided by the use of high range water-reducing admixtures, and a low water-to-powder ratio [57]. With regard to the  $w/cm$  (including mineral admixtures) and the dosage of high range water-reducing admixture, as shown in Fig.35, if proper ranges of relative funnel velocity ratio and relative flow area ratio are targeted by adjusting the  $w/cm$  and the dosage of high range water-reducing admixture, self-compacting concrete can be produced [61]. For example, the flowability increases as the dosage of superplasticizer increases, but the deformability of the material also increases. If the dosage becomes less, resistance to segregation increases. Thus, there is an optimum dosage of the admixture for self-compacting nature.

Superplasticizer			
Coarse aggregate	Fine aggregate	Water	Powder (cement)
50% of total apparent volume	upper limit of 40%	moderate	compatible of deformation and viscosity
fixation		Adjustment by the test	

Fig. 34 Mix design of SCC by Okamura and Ozawa [60].

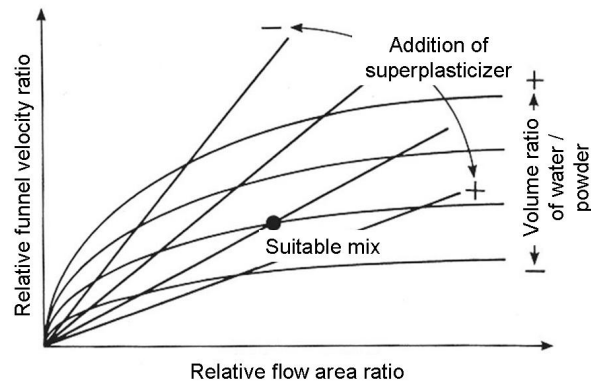

Fig. 35 Mix design by addition of superplasticizer and volume ratio of water/powder ratio [60].

### 3.2 Evaluation of self compactibility

The slump flow test will give an indication of the self-compactibility, but the resistance to passing through a gap between rebars in real cases cannot be evaluated by this test. It has been studied whether it can be evaluated by the flow curve which indicates the relationship between shear rate and shear stress, but it was not realized. Then “U-shape test method” was proposed in which the self-compactibility can be quantitatively expressed by the height of concrete rise having passed through an obstacle [62] [63]. If concrete is too stiff, it does not rise to the opposite side, but even it is too soft, coarse aggregate segregated from the mortar clogs at the obstacle and concrete does not pass and the front of concrete does not rise. Only concrete having a proper consistency is able to rise.

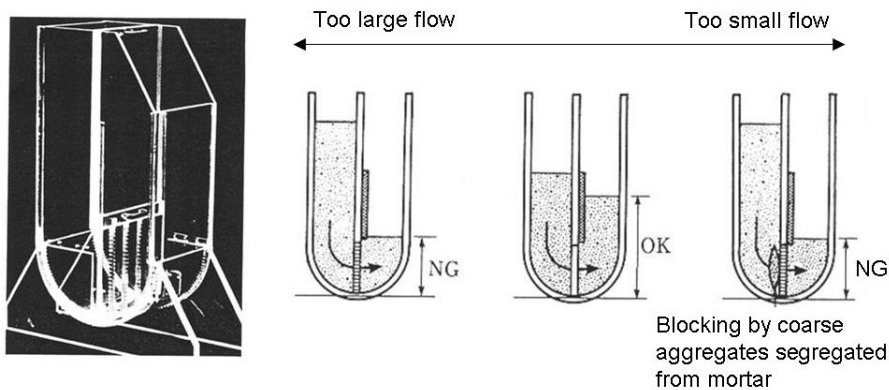

Fig. 36 U-shape test method apparatus (Shintosh method)[62] [63].

Shintosh confirmed self-compactibility by using this test for many concrete mixtures having the water-to-binder ratio of 32 % - 36 %, unit binder content of  $400 \text{ kg/m}^3 - 500 \text{ kg/m}^3$ , s/a(sand/aggregate: the ratio of fine to aggregate) of 45 % -48 %, and viscosity enhancing admixture of 0 % -1 %, and found that the target fill height,  $U_h$ , of not less than 30 cm, which is an

indication of proper self-compactability, can be achieved if the slump flow is in the range 60 cm - 70 cm. The ability of passing through the gap can be evaluated by this Shintosh test method. It was a breakthrough contribution that control of the self-compactability of SCC (Self-compacting concrete) was found to be achieved by the fill height instead of the slump flow that had been used conventionally.

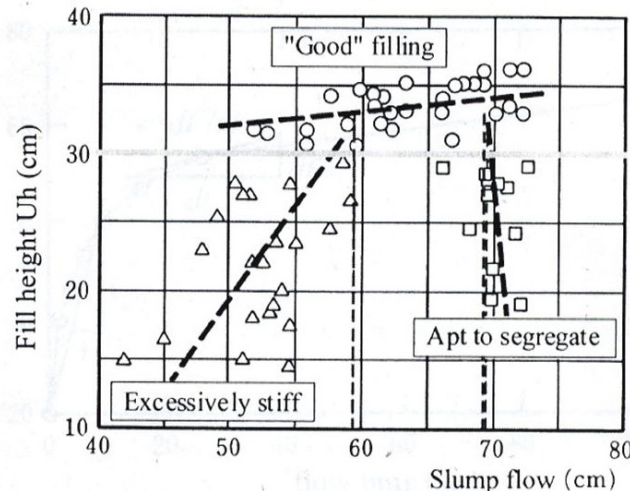

Fig.37 Acceptable range of slump flow value of SCC with good self compacting concrete [62] [63].

### 3.3 Superplasticizer for SCC

Although naphthalene sulfonate based superplasticizers were used initially [64], some drawbacks such as set-retarding phenomenon due to high dosage, loss in the flow at a low dosage, or increased load on the mixer caused by a high plastic viscosity, were observed. In response to those needs for a new chemical admixture, a polycarboxylic acid-based admixture was developed [65]. This is already stated in section 1.2. With regard to practical application of the polycarboxylic acid-based admixture, effectiveness of the methacrylic-acid-based graft copolymer having a polyoxyethylene chain, has been confirmed [66] [67] [68] [69] [70] [71]. There is also a maleate-based type of polycarboxylic-acid based AE and high range water-reducing admixture [72]. The flowability of the concrete given by this admixture, is obtained by dispersion of cement particles. The AE and high range water-reducing admixture is adsorbed on the surface of cement particles and contributes to dispersion of cement particles by its electrostatic repulsive force and steric hindrance repulsion. For the naphthalene-based admixture, dispersion due to the former effect is dominant, and for the polycarboxylic acid-based admixture, dispersion due to the latter is dominant. Therefore, reduction in plastic viscosity, and reduction of dosage, made it possible to avoid set retardation and reduction in flow loss, and thus contributed to the realization of the performance of self-compacting concrete. The period of development of polycarboxylic acid-based AE and high range water-reducing admixture overlapped the

period of development and diffusion of self-compacting concrete, and it can be understood that the emergence of polycarboxylic acid-based AE and high range water-reducing admixture was an indispensable element for the development of self-compacting concrete.

## References

- [1]K.Noguchi,[http://bme.t.u-tokyo.ac.jp/members/ippei/Research/RPCMIX/1213\\_Fluidiy/12\\_Fluidity\\_study.htm](http://bme.t.u-tokyo.ac.jp/members/ippei/Research/RPCMIX/1213_Fluidiy/12_Fluidity_study.htm)
- [2] Y. Yamada.:Study on the rheology of fresh concrete, Cement and Concrete (Japan cement association), No.707 (2006.1) 18-27
- [3] Y. Yamada, J. Tomiyama, Study on constitutive equation for viscoplastic fluid in consideration of hysteresis, Proceedings of the Japan Concrete Institute 25 (1) (2003) 899-904
- [4] Report of technical committee for mechanical model of fresh concrete, Japan Concrete Institute, p.7, (1996.4)
- [5] H.Uchikawa, S.Uchida, S.Hanehara, Flocculation structure of fresh cement paste determined by sample freezing – back scattered electron image, *Il Cemento*, 84 (1987) 3-22
- [6] C.K. Park, M.H. Noh, T.H. Park,Rheological properties of cementitious materials containing mineral admixtures, *Cem Concr Res* 35 (2005) 842-849
- [7] H.Uchikawa, Characterization and materials design of high-strength concrete with superior workability, *CEMENT TECHNOLOGY* edited by E.M.Gartner and H.Uchikawa, *Cemceramic Transaction(ACerS)*, 40 (1990) 143-186,
- [8] H.Uchikawa, S.Hanehara, H. Hirao, Cement for high-strength concrete with superior workability prepared by adjusting the composition and particle size distribution, *Journal of Research of the Taiheiyo Cement Corporation* 46 (1) No.126 (1993) 48-55
- [9]M. Collepardi, V.S. Ramachandran, 9<sup>th</sup> Int Cong on the Chem Cem (1992)
- [10]Nippon Shokubai Co., Ltd., Cement Dispersant, JP Sho 59-18338, 1981
- [11]E. Sakai, A. Ishida, A. Ota, New trends in the development of chemical admixtures in Japan, *J Adv Concr Tech*, 4 (2) (2006) 211-223
- [12]E. Sakai, K. Yamada, A. Ota, Molecular structure and dispersion-adsorption mechanisms of comb-type superplasticizers used in Japan, *J Adv Concr Tech* 1 (1) (2003) 16-25
- [13]A. Ota, T. Sugiyama, Y. Tanaka, Fluidizing mechanism and application of polycarboxylate-based superplasticizers, V.M. Malhotra (Ed.), 5<sup>th</sup> CANMET/ACI Int Conf on Superplasticizers and Other Chemical Admixtures in Concrete, SP-173, ACI, (1997) 359-378
- [14]D. Hamada, T. Hamai, M. Shimoda, M. Shonaka, New superplasticizer providing ultimate workability, *Proc of JCI* 28 (1) (2006) 185-190
- [15]S. Okazawa, A. Ota, Current status and future direction of advanced



- superplasticizers in Japan, T.W. Bremner (Ed.) Kenji Sakata Symp on Prop of Concr, 2006, pp. 331-344
- [16]R. Tomita, T. Goto, K. Sakai, K. Moniwa, An experimental study on drying shrinkage and crack of concrete using cement-shrinkage-reducing agent, Proc of JCI, (1983) 181-184
- [17]N.S. Berke, M.P. Dallaire, M.C. Hicks, A. Kerkar, New developments in shrinkage-reducing admixtures, V.M. Malhotra (Ed.) 4<sup>th</sup> CANMET/ACI Superplasticizers and Other Chemical Admixtures in Concrete, SP-173, ACI, (1997) 971-998
- [18]M. Tanimura, M. Suzuki, I. Maruyama, R.Sato, Improvement of time-dependent flexural behavior in RC members by using low shrinkage-high strength concrete, Proc 7<sup>th</sup> Int Symp on the Utilization of High Strength/High Performance Concrete, SP-228, ACI, Washington, D.C., (2005) 1373-1395
- [19]T. Sugiyama, A. Ota, Y. Tanaka, Shrinkage reduction type of advanced superplasticizer, 4<sup>th</sup> CANMET/ACI Int Conf on Adv in Concr Tech, SP-179, ACI, (1998) 189-200
- [20]K. Yamada, H. Nakanishi, S. Tamaki, M. Yaguchi, M. Kinoshita, S. Okazawa, Working mechanism of a shrinkage-reducing superplasticizer of new generation, V.M. Malhotra (Ed.), Proc 7<sup>th</sup> CANMET/ACI Conf on Recent Adv in Concr Tech, SP-222, ACI, (2004) 171-184
- [21]Y. Okawa, M. Fukushima, H. Yamamiya, Study on DELVE system, NMB Transaction, 12 (1998) 11-21
- [22]K. Yamada, T. Takahashi, S. Hanehara, M. Matsuhisa, Effects of the chemical structure on the properties of polycarboxylate-type superplasticizer, Cem Concr Res 30 (2000) 197-200
- [23]K. Yamada, S. Hanehara, Working mechanism of polycarboxylate superplasticizer considering the chemical structure and cement characteristics, Proc 11<sup>th</sup> Int Cong on the Chem of Cem 2 (2003) 538-549
- [24]R.J. Flatt, Dispersion forces in cement suspensions, Cem Concr Res 34 (3) (2004) 399-408
- [25]H. Uchikawa, S. Hanehara, D. Sawaki, The role of steric repulsive force in the dispersion of cement particles in fresh paste prepared with organic admixture, Cem Concr Res 27 (1) (1997) 37-50
- [26]K. Yoshioka, E. Sakai, M. Daimon, A. Kitahara, Role of steric hindrance in the performance of superplasticizers for concrete, J Am Ceram Soc 8 (10) (1997) 2667-2671
- [27]D.H. Napper, Steric Stabilization, J Colloid Interface Sci 58 (1997) 390-407
- [28]E. Sakai, M. Daimon, Dispersion mechanisms of alite stabilized by superplasticizers containing polyethylene oxide graft chains, V.M. Malhotra (Ed.), Proc of 5<sup>th</sup> CANMET/ACI Int Conf on Superplasticizers and Other Chemical Admixtures in Concrete, SP-173, ACI, (1997) 187-201
- [29]K. Hattori, Mechanism of slump loss and its control, Material 29 (1980) 240-246
- [30]K. Yamada, S. Hanehara, Interaction mechanism of cement and

- superplasticizers – The role of polymer adsorption and ionic conditions of aqueous phase, *Concr Sci and Eng* 3 (2001) 135-145
- [31]K. Yamada, S. Hanehara, T. Yanagisawa, Influence of temperature on the dispersibility of polycarboxylate type superplasticizer for highly fluid concrete, J.G. Gabrera, R. Rivera-Villalreal (Eds.), *Proc of Int Conf on Self-Compacting Concrete*, RILEM, Stockholm, (1999) 437-448
- [32]A. Tagnit-Hamou, P.C. Aitcin, Cement and superplasticizer compatibility, *World Cem* 24 (8) (1993) 38-42
- [33]P.C Aitcin, C. Jolicoeur, J.G. MacGregor, Superplasticizers: How they work and why they occasionally don't, *Concr Int* 5 (1994) 45-52
- [34]V. Fernon, A. Vichot, N. Le Goanvic, P. Combet, F. Corazza, U. Costa, Interaction between portland cement hydrates and polynaphthalene sulfonates, V.M. Malhotra (Ed.), *Proc of 5<sup>th</sup> CANMET/ACI Int Conf on Superplasticizers and Other Chemical Admixtures in Concrete*, SP-173, ACI, (1997) 225-248
- [35]F. Massazza, U. Costa, Effects of superplasticizers on the C3A hydration, *Proc of 7<sup>th</sup> Int Cong on the Chem Cem, Paris, IV* (1980) 271-277
- [36]D. Bonen, S.L. Sarkar, The superplasticizer adsorption capacity of cement pastes, pore solution composition, and parameters affecting flow loss, *Cem Concr Res* 25 (7) (1995) 1423-1434
- [37]T. Nawa, H. Eguchi, Y. Fukaya, Effect of alkali sulfate on the rheological behavior of cement paste containing a superplasticizer, V.M. Malhotra (Ed.), *Proc of 3<sup>rd</sup> CANMET/ACI Int Conf on Superplasticizers and Other Chemical Admixtures in Concrete*, SP-119, ACI, (1989) 405-424
- [38]Y. Nakajima, T. Goto, K. Yamada, A practical model for the interactions between hydrating portland cements and poly-beta-naphthalene sulfonate condensate superplasticizers, *J Am Ceram Soc* 88 (4) (2005) 850-857
- [39]K. Yamada, T. Sugamata, H. Nakanishi, Fluidity performance evaluation of cement and superplasticizer, *J Adv Concr Tech* 4 (2) (2006) 241-250
- [40]S. Hanehara, K. Yamada, J. Saunders, Trends of blended cement, *World Cem* (10), (11) (2005)
- [41]A. Ohno, M. Nakamura, Adsorbing behavior of polycarboxylate-type superplasticizer on belite-rich portland cement, *Cem Sci and Concr Tech* 50 (1996) 892-897
- [42]K. Yamada, S. Ogawa, S. Hanehara, Controlling the adsorption and dispersing force of polycarboxylate-type superplasticizer by sulfate ion concentration in aqueous phase, *Cem Concr Res* 31 (2001) 375-383
- [43]K. Yamada, T. Takahashi, S. Ogawa, S. Hanehara, Molecular structure of the polycarboxylate-type superplasticizer having tolerance to the effect of sulfate ion, *Cem Sci and Concr Tech* 54 (2000) 79-86
- [44]K. Yamada, K. Okada, H. Ozu, M. Yano, Polycarboxylate-type superplasticizer of which performance is enhanced by sulfate ion, *Proc of JCI* 23 (2) (2001) 79-84
- [45]K. Yamada, S. Hanehara, Incompatibility phenomena between cement and superplasticizer and its prevention method, *Proc 1<sup>st</sup> fib Cong* 7 (2002) 203-212

- [46]K. Yamada, S. Hanehara, K. Honma, Effects of initial hydration reactivity of cement on the dispersing performance of polycarboxylate superplasticizer, *Conc Library of JSCE* 38 (2001) 71-80
- [47]K. Ichitsubo, M. Ichikawa, S. Sano, The effects of the kind and amount of calcium sulfate on the initial hydration of cement and fluidity under the existence of polycarboxylate superplasticizer, *Proc of JCA* 58 (2004) 46-53
- [48]K. Yamada, C. Kim, K. Ichitsubo, M. Ichikawa, Combined effects of cement characteristics on the performance of superplasticizers –An investigating in real plants, V.M. Malhotra (Ed.), *Supplemental Volume of 8<sup>th</sup> CANMET/ACI Int Conf on Superplasticizers and Other Chemical Admixtures*, ACI, 2006 (in press)
- [49]T. Nakano, M. Ichikawa, S. Susumu, K. Ichitsubo, Effect of cooling speed of clinker on the mortar fluidity, *Proc of JCA* 60 (2006) 26-27
- [50]A. Tagnit-Hanou, S. Bouraoui, Effect of alkali sulfate on cement hydration at low and high water cement ratios, *Proc 10<sup>th</sup> Int Cong on the Chem of Cem*, H. Justnes (Ed.), Amarkai AB and Congrex Goeteborg, 1997, 2ii012
- [51]K. Ichitsubo, C-Y. Lin, K. Yamada, M. Ichikawa, Influence of grinding aids on the fluidity of cement and effect of grinding process for cement at the high temperature, *Cem Sci and Concr Tech* 59 (2005) 66-73
- [52]P. Sandberg, L.R. Roberts, Studies of cement –Admixture interaction related to aluminate hydration control by isothermal calorimetry, V.M. Malhotra (Ed.), *Proc of 7<sup>th</sup> CANMET/ACI Int Conf on Superplasticizers and Other Chemical Admixtures in Concrete*, SP-, ACI, (2003) 529-543
- [53]W. Fajun, M.W. Grutzeck, D. M. Roy, The retarding effects of fly ash upon the hydration of cement pastes: the first 24 hours, *Cem Concr Res* 15 (1985) 174-184
- [54]K. Yamada, H. Hirao, H. Yamashita, T. Nozaki, New incompatibility problem of hardening under specific combination among chemical admixtures, cement and fly ash, *Proc 12<sup>th</sup> Int Cong on the Chem Cem* (2007) (in submission)
- [55]D. Atarashi, E. Sakai, R. Obinata, M. Daimon, Influence of clay minerals on fluidity of CaCO<sub>3</sub> suspension containing comb-type polymer, *Cem Sci and Concr Tech* 57, (2003) 386-391
- [56]E. Sakai, D. Atarashi, A. Kawakami, M. Daimon, Influence of molecular structure of comb-type superplasticizers, V.M. Malhotra (Ed.), *Proc of 7<sup>th</sup> CANMET/ACI Int Conf on Superplasticizers and Other Chem Adm in Concr*, SP-217, ACI, (2003) 381-392
- [57]A.A. Jeknavorian, L. Jardine, C.C. Ou, H. Koyata, K. Folliard, Interaction of superplasticizers with clay- bearing aggregates, V.M. Malhotra (Ed.), *Proc of 7<sup>th</sup> CANMET/ACI Int Conf on Superplasticizer and Other Chem Adm in Concr*, SP-217, ACI, (2003) 143-159
- [58]H.Okamura, K.Maekawa, K.Ozawa, High performance concrete (self compacting concrete), Gihodo Publisher, (1993.9)
- [59] Self compacting and high performance concrete, edited by H.Okamura, Institute of social system, (1999)

- [60] M.Oouchi, Self-compacting concrete technology from Japan to the world, Civil Engineering (JCSE) ISSN 0021-468X, 86 (4) (2001) 58-62
- [61] M.Oouchi, Flowable self-compacting concrete, Concrete Technology(JCI) ISSN 0387-1061, 40 (1) (2002) 62-67
- [62] Manual of how to produce self compacting concrete, ZENNAMA(Japan), (1998.7)
- [63]T.Shindou: Research on super workable concrete using anti-segregation agent, Dessertation, the university of Tokyo, (1993.9)
- [64]T. Shindoh, Y. Matsuoka, Development of combination-type self-compacting concrete and evaluation test methods, JI Adv Concr Tech.1 (1) (2003) 26-36
- [65] K.Kishitani, N.Kunigawa, M.Iizuka, T.Mizunuma, Cement & Concrete (JCA) ISSN 0371-0718, No.478, (1986) 12
- [66] M.Kinoshita, Role and progress of organic admixture for concrete, Nippon Gomu Kyokaisi(SRIJ), 78 (7) (2005) 267-272
- [67] M.Kinoshita, S.Yamaguchi, T.Yamamoto, F.Tomosawa, Cement science and concrete technology(JCA), No.44, (1990) 222-227
- [68] M.Kinoshita, T.Yonezawa and Y.Yuki, Cement science and concrete technology(JCA), No.47, (1993) 196-201
- [69] M.Kinoshita, Y.Yuk, Y. Miura and T.Takahashi,Japanese Journal of Polymer Science and Technology, 52 (1) (1995) 33
- [70] M.Kinoshita, Y.Yuki, K.Saito and T.Takahashi, Japanese Journal of Polymer Science and Technology, 52 (6) (1995) 357
- [71] Kinoshita M., Suzuki T., Yonezawa T., Mitsui K, Properties of an acrylic graft copolymer-based new superplasticizer for ultra high-strength concrete, American Concrete Institute, SP-148, (1994) 281-299
- [72] Mitsui K, Yonezawa T, Kinoshita M., Shimono T, Application of a new superplasticizer for ultra high-strength concrete, American Concrete Institute, SP-148, (1994) 27-45
- [73] T.Sugamata, The particle dispersing of polycarboxylate-based superplasticizers on the consideration to the changing of cement particles, Dessertation, the university of Tokyo, (1999.3)